

Max. Flow Rate: 158 GPH (600 LPH)

- Separ 2000 series water separators fuel filters are a simple solution to many different fuel related problems.
- Five separate stages of filtration ensure 99.9% water separation (Certified TUV Report using SAE J1839) at maximum flow.
- Low restriction reduces wear on fuel pumps and ensures full RPMs.
- Backflushable (cleanable) element reduces down time and costly element changes.
- Marine version with U.S. Coast Guard-accepted metal heat deflector.

INDUSTRIAL



MARINE



Shown: Industrial (left to right) 2000/10, 2000/10U
Marine (left to right) 2000/10D-G, 2000/10UD-G

Inlet / Outlet Connections

Single Unit: 7/8-14 Straight o-ring SAE
Duplex Unit: Shipped with #8 Male JIC Flare
(other adapters available)
Inlet and Outlet Pipe connection 15mm.

Ordering Specifications

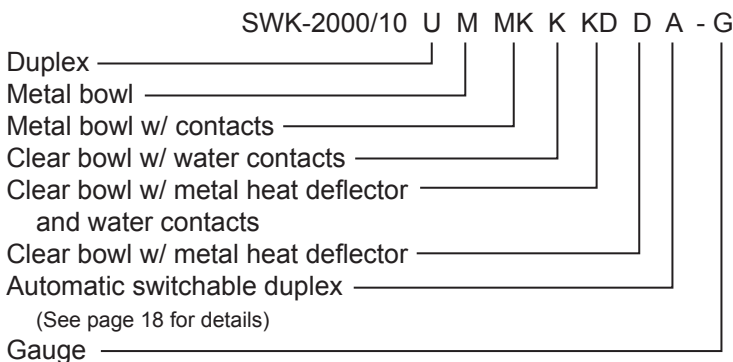

We reserve the right to alter the specification without prior notice.

Pressure Drop

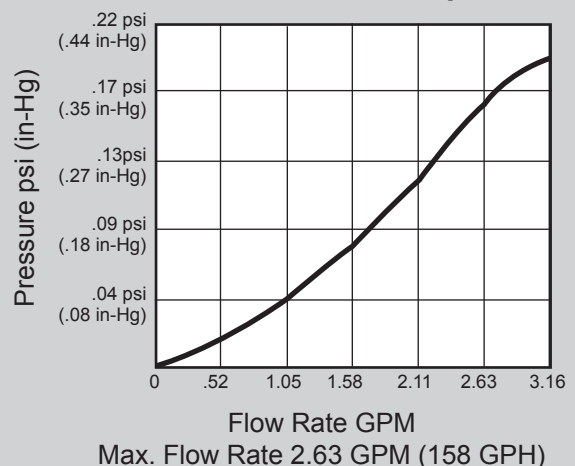

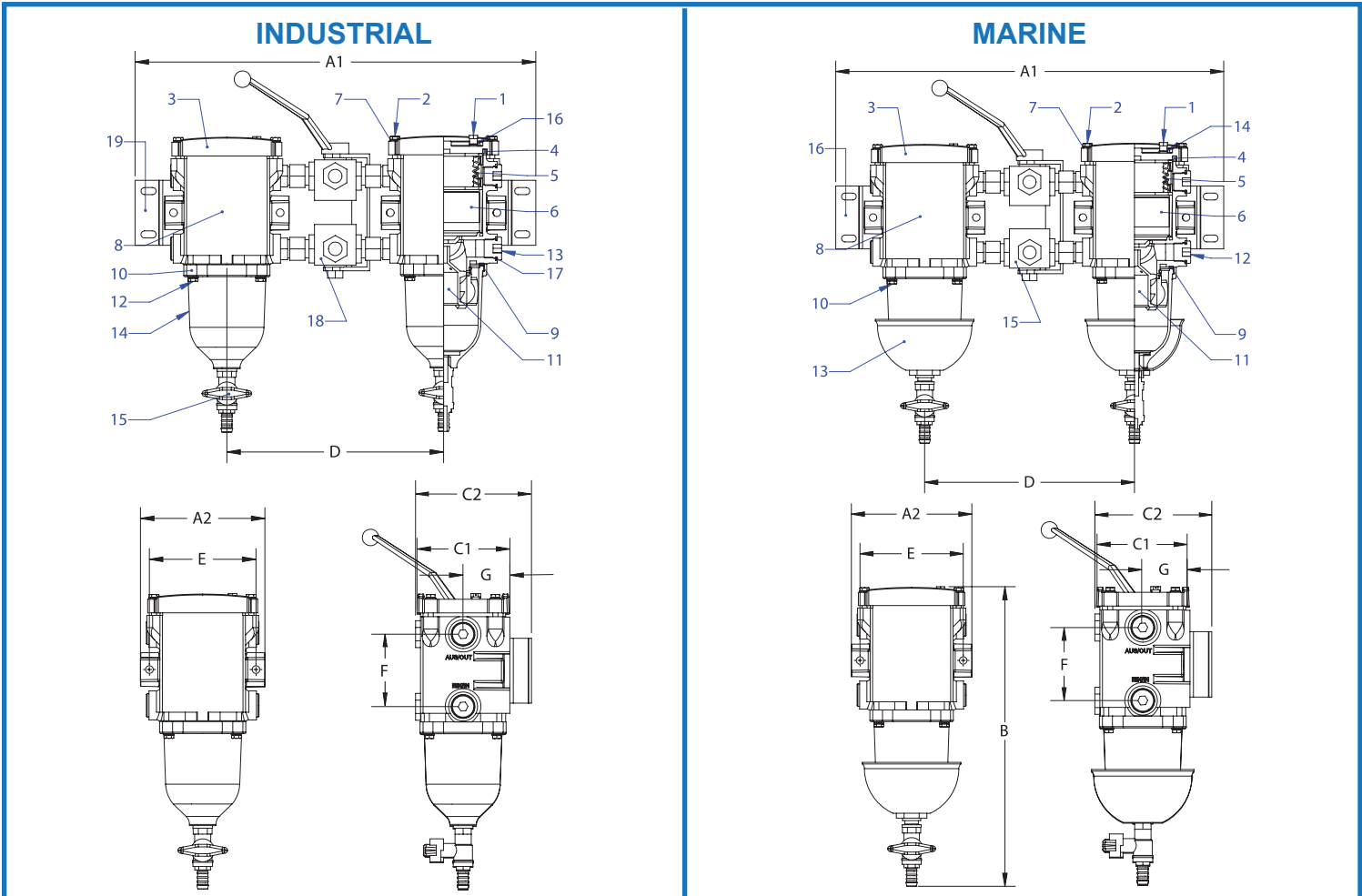

Item	Part #	Description	Dimension		Item	Part #	Description	Dimension	
1	30408	Bleed Screw	A1	18.5"	1	30408	Bleed Screw	A1	18.5"
2	FAB-51822	Lid Screw		(469.9mm)	2	FAB-51822	Lid Screw		(469.9mm)
3	30553	Lid	A2	5.75"	3	30553	Lid	A2	5.75"
4	10362	Lid Gasket		(146mm)	4	10362	Lid Gasket		(146mm)
5	30297	Spring Frame	B	13.65"	5	30297	Spring Frame	B	13.65"
6		<u>Filter Element</u>		(346.8mm)	6		<u>Filter Element</u>		(346.8mm)
	01010	10 Micron	C1	4.29"		01010	10 Micron	C1	4.29"
	01030	30 Micron (standard)		(109mm)		01030	30 Micron (standard)		(109mm)
	01060S	60 Micron (stainless steel)	C2	5.37"		01060S	60 Micron (stainless steel)	C2	5.37"
				(136.4mm)					(136.4mm)
7	30448	Washer	D	10"	7	30448	Washer	D	10"
8	30552	Housing		(254mm)	8	30552	Housing		(254mm)
9	10361	Bowl Gasket	E	4.92"	9	10361	Bowl Gasket	E	4.92"
10	30569	Bowl Retaining Ring		(125mm)	10	30568	Bowl Screw		(85mm)
11	30563	Centrifuge	F	3.35"	11	30563	Centrifuge	F	3.35"
12	30568	Bowl Screw		(85mm)	12	6408-10	Plug		(55.1mm)
13	6408-10	Plug	G	2.17"	13		<u>Bowl Assembly</u>		
14	30985	Clear Bowl				30989W	Single Unit (white)		
15	30366	Drain Valve				30989	Duplex Unit (grey)		
16	30558	Bleed Screw Gasket	Model Weight		14	30558	Bleed Screw Gasket	Model Weight	
17	6408-10	Plug O-Ring	SWK-2000/10	6 lbs	15	2000_10-VA	Reversing Valve Assembly	SWK-2000/10D	6.5 lbs
18	30476	Reversing Valve Assembly		(2.72 kg)	16	30477	Mounting Bracket		(2.95 kg)
19	30477	Mounting Bracket	SWK-2000/10U	18.5 lbs				SWK-2000/10UD	19.5 lbs
				(8.39 kg)					(8.85 kg)