



# CCS 3200 COMPRESSOR CONTROL SYSTEM

USER MANUAL

FATİH DALOĞLU

## Güvenlik Uyarısı

### CCS 3200 DESCRIPTION

CCS 3200 Compressor Control System is designed for screw and reciprocating compressors. CCS 3100 is a microprocessor-controlled device that performs the processes of compressor start and stop, pressure regulation, temperature control, fault monitoring and protection against faults.

### 1. SYSTEM DESCRIPTION

CCS 3100 Panel consists of keypad, led status indicators and 2x16 backlit LCD.

With the help of the buttons, you can access the fault logs, service times, pressure, temperature and voltages measured by the device, input and output states, counters related to the compressor through the menu, and also adjust the parameters of the device. There is a 3-color led indicator on the device that shows its current status.

#### 1.1 Front-End Description

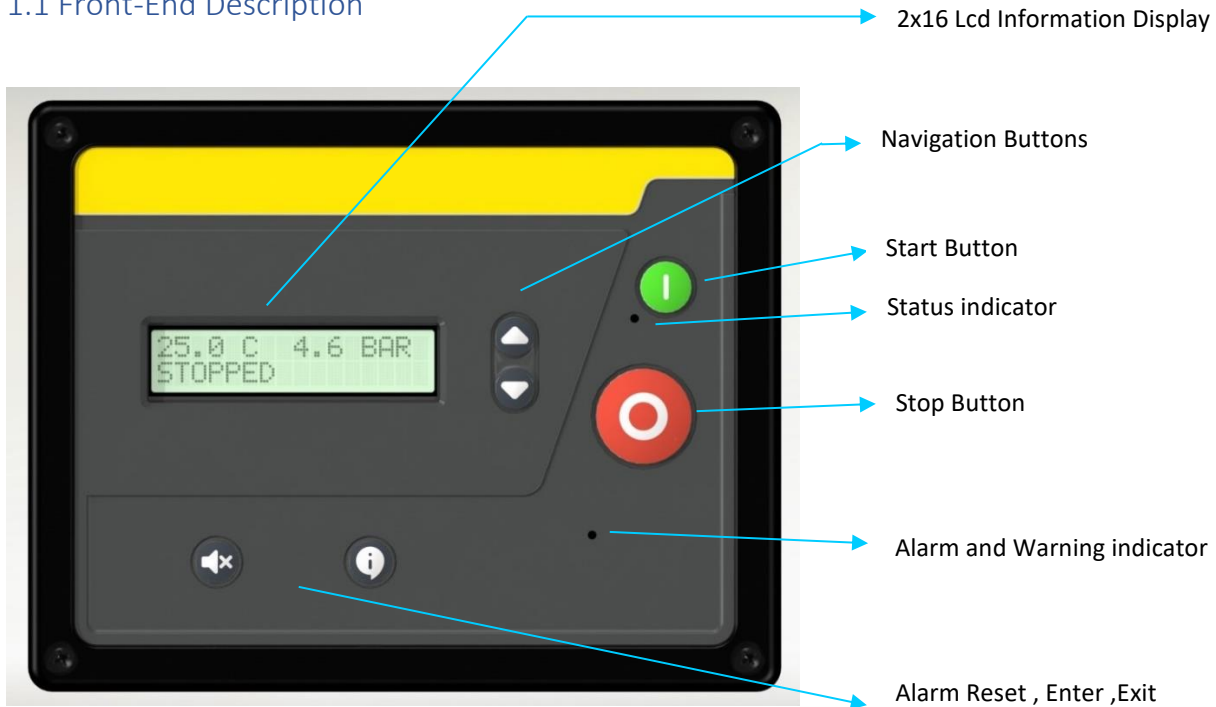

#### 1.2 Button Description



**Start Button:** Starts the compressor.



**Stop Button:** Stops the compressor.

**Up Button:**

- Switches between two pages on the main operation screen.
- When pressed while in the menu, goes to the lower indexed title or parameter.
- Increases numerical values and changes selectable values in parameter setting screen.

**Down Button:**

- Switches between two pages on the main operation screen.
- When pressed while in the menu, goes to the higher indexed title or parameter.
- Decreases numerical values and changes selectable values in parameter setting screen.

**Enter Button:**

- When pressed on the main operation screen, enters to the information menu. See 2.4 Information menu
- When pressed while in the menu, provides access to the upper and lower titles.
- When pressed while on the selected parameter, enters to the parameter setting screen.
- When pressed on the parameter setting screen, saves the set value.
- When pressed on the password entry screen, moves the cursor to the next character on right side.

**Exit / Cancel Button:**

- When pressed for 2 seconds on the main operating screen, resets the alarm.
- Enables to return from the lower title to the upper title, from the upper title to the main operation screen.
- When pressed on the parameter setting screen, in numerical values, moves the cursor to the next character on the right side. When pressed for 2 seconds, exits the setting screen without saving the parameter.

### 1.3 Led Indicator Description

There are 2 led indicators on the panel.



**Status Indicator:** Provides information about the status of the panel and the compressor.

In the table below, you can see the operation status of the Led indicator and the explanations of these status.

Led Color	Status	Explanation
Green	Continuously	If The Compressor is started with the START button , it lights up continuously, regardless of the operating status of the compressor.
Green	Flashing 0,5 sec.	After the START button is pressed, the led is flashed with a 0.5 second period while counting the Start delay time.
Green	Flashing 1 sec.	when the compressor is "Auto-Standby" operating mode. The led is flash with 1 second period.
Blue	Continuously	If the Compressor is remote start mode. When the compressor is started via Digital-input or communication, the status indicator turns blue while the motor is run.
Blue	Flashing 0,5 sec.	If the Compressor is remote start mode. the led is flashed with a 0.5 second period while counting the Start delay time.
Blue	Flashing 1 sec.	If the Compressor is remote start and "Auto-Standby" operating mode. The led is flash with 1 second period.



**Fault Indicator:** Provides information about the fault status in the panel.

In the table below, you can see the operation status of the Led indicator and the explanations of these status.

Led Color	Status	Explanation
Red	Flashing 1 sec.	Indicates a warning.
Red	Continuously	Indicates an error.
Red	Flashing 0,5 sec.	It's indicated to be in the software boot mode. (USB cable connected to PC)

## 1.4 Display and Menu Structure

### 1.4.1 Startup Screen

When the device is turned on for the first time, gives the information specified in the screen below.

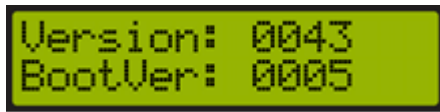

**Version:** Indicates the version of the device software

**BootVer:** The boot software version of the device

After showing the software version for 3 seconds, the device shows the company information screen below. This screen can be customized and installed to the device. See application note "**Application Note Software Update**"



After showing the company information screen for 3 seconds, the device shows the main operation screen.

### 1.4.2 Main Operation Screen

There are two display pages on the main operating screen of the device. The first is the screen where screw temperature, supply pressure and compressor status are shown. On the second screen, screw and supply pressure sensors connected to the device, screw temperature sensor and second temperature sensor values are displayed. It is possible to switch between the display pages with or buttons.

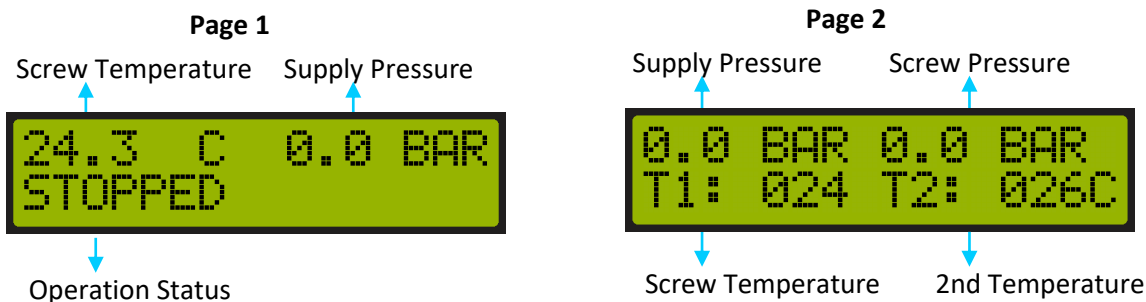

**Note:** If 2nd temperature is not activated, this section will seem empty.

### 1.4.3 Information Menu

When button is pressed on the main operation screen of device, the information screen is accessed. Information and details displayed on the information screen are as follows.

#### 1.4.3.1 Fault Logs

When button is pressed in the fault logs menu, below screen is accessed.

Alr01 expression indicates the number of the alarm. You can see the last 15 alarms, the first alarm entering to the list leaves the list first.

The expression #00002h indicates the number of total operating hours at the time of alarm occurrence.

The line at the bottom provides the alarm definition. For the alarm detail you see, see "2.6 Alarm and Warning Descriptions and solution advices".

or you can navigate through fault logs with button.



1.4.3.2 Service Times

When button is pressed in the Service Times menu, the following screens are accessed.



button

Shows how much time is left for the general maintenance service. The duration is set with P098 General maintenance parameter among the service times parameters.

button

Indicates how much time is left for bearing maintenance service. The duration is set with P099 Bearing maintenance parameter among the service times parameters.

button

Shows how much time is left for the oil change service. The duration is set with P100 Oil Change maintenance parameter among the service times parameters.

button

Shows how much time is left for the Oil Filter replacement service. The duration is set with P102 Oil Filter Replacement parameter among the service times parameters.

button

Shows how much time is left for the Oil Filter replacement service. The duration is set with P102 Oil Filter Replacement parameter among the service times parameters.

button

Shows how much time is left for Separator Filter replacement service. The duration is set with P103 Separator Filter Replacement parameter among the service times parameters.

button

```
Total Worked
Pnon> 00002 hr
```

Shows the total motor running time.



```
Onload Worked
Pnon> 00002 hr
```

Shows the motor's time at load (producing air).

### 1.4.3.3 Phase Voltages

Information regarding the 3-phase voltage and frequency connected to the device is displayed.

```
Phase Volts >> Urs=380 Ust=380
                  Utr=380 Fr =50.0
```

### 1.4.3.4 Digital I/O

Shows the input and output status of the device. If the value is "0", the corresponding input or output is passive. If it is "1", it indicates that the corresponding input or output is active.

DI: Digital Input

DO: Digital Output

```
Digital I/O >> DI: 00000000
                DO: 00000
```

### 1.4.3.5 Supply Voltage

Shows the device's own supply voltage and the output voltage value it provides for digital inputs and analog inputs (pressure sensor).

```
Supply Voltages >> Power =24.3V
                  Sensor =15.2V
```

### 1.4.3.6 Comp. Counters

Shows the counters of the compressor.

S/S = Number of runs and stops

OLT = Counts how many times the load valve has been activated.

```
Comp. Counters >> S/S = 00
                  OLT = 00006
```











## 1.4.4 Parameter Menu

The parameter menu of the device is accessed by pressing both and buttons for 3 seconds on the main screen.

```
Password: 0***
ESC +- ENTER
```

Shows at which digit "0" is. To change the number in the relevant digit, and buttons are used. button is used for the next digit, and button is used for the previous digit. After the number in the last digit is set, the password entered is confirmed with button. If the password entered is correct, the following menus can be accessed. The parameters in the menus are displayed according to the level of your access password. If your access password is not authorized to access the relevant parameter, you cannot see the parameter.

### Accessing and Changing Parameters:

After confirming the password by pressing  button, the parameter category menu is accessed.  or  buttons are used to navigate in parameter category menus. To access the parameters under the relevant parameter category,  button is used. To change the content of the related parameter, use  button on the parameter and go to parameter changing screen. In the parameter changing screen, the cursor blinks on the line where changes can be made. The value on the cursor is changed with  or  buttons. Use  to move the cursor to the Previous digit and  to move it to the next digit. To confirm the entered value, press and hold  button. To return to the previous menu without changing the value, press and hold  button.

## 1.5 Operation Status

Descriptions regarding the operating status screens of the device and the relevant parameters of these screens are as follows.

### Stopped (STOPPED)



The device waits for a run command via the start button or the remote operation input ("Application Note 002") on it.

### Start Delay (START DELAY):



The device received the run command and is waiting for the time in "P021 Start Delay" parameter to end. Countdown for the remaining time is displayed on the screen.

### Screw Pressure High (HIGH SCREW):



The device received the run command and the screw pressure value is higher than the "P007 Minimum Screw Pressure" value, it is waiting for the pressure to decrease below this value. When the pressure drops below this value, the running process continues.

### Motor is Running in Star Position (Motor Start):



The device received a run command, star and main contactor are active and the device is waiting for the end of the time entered to the "P028 Star Running time" parameter.

### Preheat Idle Operation (PREHEAT OFLD):



The device received run command and since the screw temperature is low, it is in the preheat mode and air solenoid is passive. See "Application Note Preheat". Related parameters are "P126 Preheat Limit" and "P032 Preheat idle time". Main Contactor and Delta Contactor are active.

### Preheat Running on Load (PREHEAT LOAD):



The device received run command and since the screw temperature is low, it is in the preheat mode and air solenoid is active. See "Application Note Preheat". Related parameters are "P126 Preheat Limit" and "P031 Preheat on Load time". Main Contactor and Delta Contactor are active.



Idle Run (IDLE):



The device runs the compressor in idle mode. The solenoid valve is passive and the compressor does not produce air. Seen in two different positions.

- First position, on initial run command, during "P024 idle run time" after Motor Start time.
- Second position, Compressor line pressure passed the "P002 Idle Pressure " parameter and it waits for the time entered to the "P026 Auto Waiting Delay" parameter to expire. The device runs the compressor in idle mode. The solenoid valve is passive and the compressor does not produce air. If the line pressure does not go below "P003 Onload Pressure" before the end of this period, the compressor stops.

Running on Load (ON LOAD):



The device received a run command, the solenoid valve is active and the compressor is producing air. The compressor line pressure is below the value entered to the "P002 Idle Pressure "parameter.

Switching to Load (PASS ONLOAD):



The pressure value on the device exceeded the value entered to the "P002 Idle Pressure "parameter, the pressure decreased to a level that is below the value entered to the "P003 Onload Pressure" parameter, and the device waits for the value entered to the "P25 Pass Again Onload Time" parameter to expire.

Air Discharge (AIR DISCHRG):



The device is in the phase of stopping the compressor. Main contactor, Delta Contactor are in passive mode and the device is waiting for the end of the time entered to the "P023 Air Discharge Time" parameter in order to release the air.

Automatic Waiting (Auto Waiting):



The pressure of the device exceeded the value entered to the "P002 Idle Pressure" parameter and waited during the time entered to the "P026 Auto Waiting Delay" parameter. It is waiting for the air pressure to drop below the value entered to the "P003 Onload Pressure" parameter. When the pressure drops below the related parameter, the compressor will run again. Motor stopped, Air solenoid is Passive.

Stopping (WILL STOP):



The device is in the stop state and waiting for completion of the time entered to the "P022 Stopping Time" parameter. Air Solenoid is passive, motor contactors are active.

Idle Run Position Number of Starts Per Hour Exceeded (IDLE (SSL)):



Compressor line pressure passed the "P002 Idle Pressure" parameter and it waits for the time entered to the "P026 Auto Waiting Delay" parameter to expire. The device runs the compressor in idle state and run in idle state for a period that is bigger than the value entered to the "P158 Maximum Number of Starts Per

Hour” parameter within 1 hour. The solenoid valve is passive and the compressor does not produce air. If the line pressure does not go below “P003 Onload Pressure” before the end of this period, the compressor stops.

## 1.6 Alarm and Warning Descriptions and Solution Advices

### 1.6.1 Digital Input Faults

Digital inputs define the inputs of the device including terminals 12-20, which are identified as DI1 to DI8. Relevant inputs are shown in the diagram below. You can see the same diagram on the label on the back of the device.

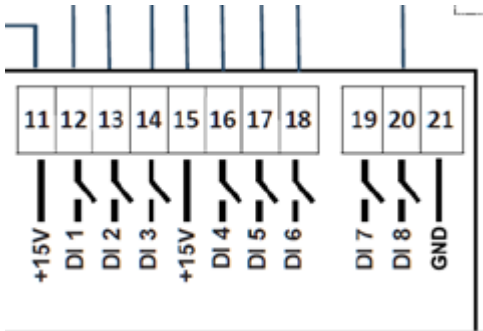

Common actions to be taken in all digital input faults:

- Digital input assignments of the device can be changed later. For digital input faults, the first thing to do is to determine which digital input the related fault is assigned to.
- After detecting the input to which the digital input fault is assigned, make sure that the equipment connected to the relevant input transmits the + 15V signal coming out from the terminals 11 and 15 when the device is active.
- Make sure that the contact type of the input to which the digital fault is assigned is defined correctly.
- Make sure that there is no problem in the wiring between the terminal of the corresponding output and the terminals 11 and 15 of the device.
- Make sure that the equipment connected to the corresponding output is working properly.
- Check that the + 15V signal coming out from the terminals 11 and 15 of the device is not short-circuited to another signal with a faulty connection.

**Important note:** It is recommended that the function parameters of the unused inputs of the device are selected as "None" and the Contact Type parameters are selected as "NO" normally open.

**Important Note:** 15 Vdc voltage is generated from terminals 11 and 15 of the device, which are defined as +15V. These voltages is used for equipment to be connected to the inputs of the device. No external voltage should be applied to these terminals. If applied, the device will malfunction and will be out of warranty.

#### 1.6.1.1 Emergency Stop (Emergency Stop)



**Fault Definition:** It is a malfunction that stops the compressor rapidly.

**Possible Causes and required actions:** The emergency stop button may have been pressed. Contact type may be wrong. Check that the terminal of the Emergency stop button is correctly connected to terminal “DI1” 12, which is the default input, and that the signal is transferred from terminals 11 and 15 to the corresponding input when the contact is closed.

#### 1.6.1.2 Separator Filter (Separator Filter)



**Fault Definition:** It is a malfunction that stops the compressor rapidly.

**Possible Causes and required actions:** Filter sensor contact may have been activated due to a clogging on the separator. The sensor may be malfunctioning. Contact type may be wrong. Check that the terminal of the separator filter contact terminal is correctly connected to terminal “DI3” 14, which is the default input, and that the signal is transferred from terminals 11 and 15 to the corresponding input when the contact is closed.

#### 1.6.1.3 Oil Pressure (Oil Pressure)



**Fault Definition:** It is a malfunction that stops the compressor rapidly.

**Possible Causes and required actions:** The sensor contact may have been activated due to low oil pressure level. The sensor may be malfunctioning. Contact type may be wrong. Check that the terminal of the oil pressure contact terminal is correctly connected to terminal “DI5” 17, which is the default input, and that the signal is transferred from terminals 11 and 15 to the corresponding input when the contact is closed.

#### 1.6.1.4 Phase Sequence – DI (Phase Seq – DI)



**Fault Definition:** It is a malfunction that stops the compressor rapidly.

**Possible Causes and required actions:** Motor phases may be connected incorrectly. The contact of the phase sequence relay may have been activated. Contact type may be wrong. Phase sequence relay may have malfunctioned. Check that the terminal of the Phase sequence relay contact terminal is correctly connected to terminal “DI4” 16, which is the default input, and that the signal is transferred from terminals 11 and 15 to the corresponding input when the contact is closed. Check the phase connections.

**Important note:** If the motor voltage connection is directly connected to the CCS3200 without using a phase protection relay, the Input function 4 parameter P56 must be selected as “None” from the Digital Input parameters.

#### 1.6.1.5 Motor Thermic Relay (Motor Thermic)



**Fault Definition:** It is a malfunction that stops the compressor rapidly.

**Possible Causes and required actions:** Motor protection thermic relay may have been activated. Contact type may be wrong. Check that the terminal of the Motor Thermic Relay contact terminal is correctly connected to terminal “DI2” 13, which is the default input, and that the signal is transferred from terminals 11 and 15 to the corresponding input when the contact is closed.

#### 1.6.1.6 Fan Thermic Relay (Fan Thermic)



**Fault Definition:** It is a malfunction that stops the compressor rapidly.

**Possible Causes and required actions:** Fan Motor protection thermic relay may have been activated. Contact type may be wrong. Check that the terminal of the Fan Motor Thermic Relay contact terminal is correctly connected to terminal "DI8" 20, which is the default input, and that the signal is transferred from terminals 11 and 15 to the corresponding input when the contact is closed.

#### 1.6.1.7 PTC Alarm (PTC Alarm)



**Fault Definition:** It is a malfunction that stops the compressor rapidly.

**Possible Causes and required actions:** The temperature of the motor may have exceeded the specified limits. The PTC connected to the device may have malfunctioned. The used PTC may not be compatible with the device. Make sure that the motor PTC is connected to terminal "DI7" 19 and terminal "GND" 21.

#### 1.6.1.8 Custom - 1 Alarm (Custom - 1 Alarm)



**Fault Definition:** It is a malfunction that stops the compressor rapidly.

**Possible Causes and required actions:** There may be a signal coming to the terminal to which the backup fault 1 function is assigned. Contact type may be wrong. Check that the terminal of the contact of equipment connected to the terminal to which the relevant fault is assigned is correctly connected and that the signal is transferred from terminals 11 and 15 to the corresponding input when the contact is closed.

#### 1.6.1.9 Custom - 2 Alarm (Custom - 2 Alarm)



**Fault Definition:** It is a malfunction that stops the compressor rapidly.

**Possible Causes and required actions:** There may be a signal coming to the terminal to which the backup fault 2 function is assigned. Contact type may be wrong. Check that the terminal of the contact of equipment connected to the terminal to which the relevant fault is assigned is correctly connected and that the signal is transferred from terminals 11 and 15 to the corresponding input when the contact is closed.

#### 1.6.1.10 Door Open



**Fault Definition:** It is a malfunction that stops the compressor rapidly.

**Possible Causes and required actions:** Fault indicating that the panel door of the compressor is open. Check that the terminal of the contact of equipment connected to the terminal to which the relevant fault is assigned is correctly connected and that the signal is transferred from terminals 11 and 15 to the corresponding input when the contact is closed.

### 1.6.2 Analog Input Faults

Analog inputs define the inputs connected to terminals 3-10, which are defined as AN4, AN3, AN2, AN1; and terminals 22-25, which are defined as N, T, S, R. Relevant inputs are shown in the diagram below. You can see the same diagram on the label on the back of the device.

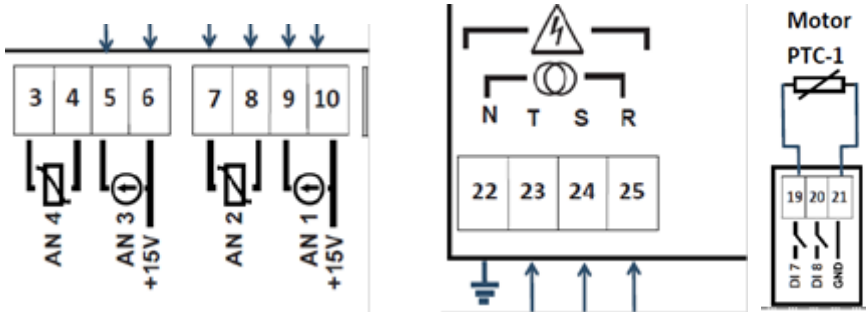

#### 1.6.2.1 Phase Sequence Error Analog (Phase Seq - AI)



**Fault Definition:** Indicates that the sequence of the 3-phase voltage connected to the terminals 22,23,24 and 25 of the device, which are defined as N, T, S, R, is incorrect. It is a malfunction that stops the compressor rapidly.

**Possible Causes and required actions:** Phases connected to the R-S-T terminals of the device may have been connected incorrectly. There may be a problem with the cable connection. Enter the Phase Voltages screen on the information screen of the device and check whether there is an unbalance in the voltage values.



#### 1.6.2.2 Line Sensor Error (Line Sens Alarm)



**Fault Definition:** Indicates that there is a problem in the connection of line pressure sensor that is connected to the terminals 9-10 of the device, which are defined as AN1. It is a malfunction that stops the compressor rapidly.

**Possible Causes and required actions:** The line pressure sensor connected to the relevant terminal may be defective or there may be a problem in the cable connections.

Additionally, the supply and sensor voltages must be checked from the screen below. If the supply voltage is outside of the 14-16V range, the transformer used to supply the panel, and its connections, must be checked. If the sensor voltage is outside of the 14-16V range, terminals 6, 10, 11 and 15 of CCS3200, the wiring going to the sensors, and the sensors themselves, should be checked for any short-circuits or other fault conditions, which should be fixed.

If the root cause cannot be determined with the aforementioned steps, all the sockets should be removed from terminals 3 through 21 of CCS3200 and the sensor voltage should be checked again to confirm whether it is in the 14-16V range. If the sensor voltage recovers when the sockets are removed, this indicates a connection fault which should be fixed by reconnecting the sockets one at a time to determine the faulty connection; if not, this indicates there might be an issue with the panel, which should be sent in for service.

The sensor voltage must be higher than the minimum specified operating voltage of the pressure sensor used in the system.



1.6.2.3 Screw Sensor error (Screw Sens Alarm)



**Fault Definition:** Indicates that there is a problem in the connection of screw pressure sensor that is connected to the terminals 5-6 of the device, which are defined as AN3. It is a malfunction that stops the compressor rapidly.

**Possible Causes and required actions:** The screw pressure sensor connected to the relevant terminal may be defective or there may be a problem in the cable connections.

Additionally, the supply and sensor voltages must be checked from the screen below. If the supply voltage is outside of the 14-16V range, the transformer used to supply the panel, and its connections, must be checked. If the sensor voltage is outside of the 14-16V range, terminals 6, 10, 11 and 15 of CCS3200, the wiring going to the sensors, and the sensors themselves, should be checked for any short-circuits or other fault conditions, which should be fixed.

If the root cause cannot be determined with the aforementioned steps, all the sockets should be removed from terminals 3 through 21 of CCS3200 and the sensor voltage should be checked again to confirm whether it is in the 14-16V range. If the sensor voltage recovers when the sockets are removed, this indicates a connection fault which should be fixed by reconnecting the sockets one at a time to determine the faulty connection; if not, this indicates there might be an issue with the panel, which should be sent in for service.

The sensor voltage must be higher than the minimum specified operating voltage of the pressure sensor used in the system.



1.6.2.4 Temperature Sensor 1 Error (Temperatr1 Alarm)



**Fault Definition:** Indicates a problem in the connection of screw temperature sensor that is connected to the terminals 7-8 of the device, which are defined as AN2. It is a malfunction that stops the compressor rapidly.

**Possible Causes and required actions:** The screw temperature sensor connected to the relevant terminal may be defective or there may be a problem in the cable connections.

1.6.2.5 Temperature Sensor 2 Error (Temperatr2 Alarm)



**Fault Definition:** Indicates a problem in the connection of second temperature sensor that is connected to the terminals 3-4 of the device, which are defined as AN4. It is a malfunction that stops the compressor rapidly.

**Possible Causes and required actions:** The second temperature sensor connected to the relevant terminal may be defective or there may be a problem in the cable connections.

#### 1.6.2.6 Line Pressure Warning (Line Press Warning)

```
24.0 C 0.0 BAR
Line Press Warn
```

**Warning Definition:** Indicates that the value read by the line pressure sensor is above the value entered to the "P005 Line Warning Value" parameter. It is just a warning message. Does not stop the motor.

**Possible Causes and required actions:** Make sure that the relevant parameter is suitable for your application.

#### 1.6.2.7 Line Pressure Alarm (Line Alarm)

```
24.0 C 0.0 BAR
Line Alarm
```

**Fault Definition:** Indicates that the value read by the line pressure sensor is above the value entered to the "P004 Line Alarm Value " parameter. It is a malfunction that stops the compressor rapidly.

**Possible Causes and required actions:** Make sure that the relevant parameter is suitable for your application.

#### 1.6.2.8 Screw Pressure Warning (Screw Press Warn)

```
75.0 C 8.1 BAR
ScrewPress Warn
```

**Warning Definition:** Indicates that the value read by the screw pressure sensor is above the value entered to the "P009 Screw Pressure Warning" parameter. It is just a warning message. Does not stop the motor.

**Possible Causes and required actions:** Make sure that the relevant parameter is suitable for your application.

#### 1.6.2.9 Screw Pressure Alarm (ScrewPress Alarm)

```
75.0 C 8.6 BAR
ScrewPress Alarm
```

**Fault Definition:** Indicates that the value read by the screw pressure sensor is above the value entered to the "P008 Screw Pressure Alarm" parameter. It is a malfunction that stops the compressor rapidly.

#### 1.6.2.10 Pressure Difference Warning (Delta Press Warn)

```
75.0 C 7.6 BAR
DeltaPress Warn
```

**Warning Definition:** After the value read by the screw pressure sensor exceeds the value entered to the "P013 Sufficiency Pressure" parameter, it indicates that the value difference between the line pressure and the screw pressure exceeded the value entered to the "P012 Delta Pressure Warning" parameter. It is just a warning message. Does not stop the motor.

**Possible Causes and required actions:** Make sure that the relevant parameter is suitable for your application. There may be an air leakage in the system.

#### 1.6.2.11 Pressure Difference Fault (DeltaPress Alarm)

```
75.0 C 7.6 BAR
DeltaPress Alarm
```

**Fault Definition:** After the value read by the screw pressure sensor exceeds the value entered to the "P013 Qualification Pressure" parameter, it indicates that the value difference between the line pressure and the screw



pressure exceeded the value entered to the "P011 Pressure Difference Error" parameter. It is a malfunction that stops the compressor rapidly.

**Possible Causes and required actions:** Make sure that the relevant parameter is suitable for your application. There may be an air leakage in the system.

#### 1.6.2.12 Minimum Pressure Reached (Reached MinPress)



**Fault Definition:** It is a fault that occurs when the screw pressure measured while the compressor is running does not reach the value entered to the "P013 Sufficiency Pressure" parameter during the time entered to the "P038 Sufficiency Delay" parameter and stops the compressor rapidly.

**Possible Causes and required actions:** Make sure that the relevant parameter is suitable for your application. There may be an air leakage in the system.

#### 1.6.2.13 Screw Temperature High Warning (Temp1 Upper Warn)



**Warning Definition:** Indicates that the value read by the Screw temperature sensor connected to terminals 7-8, which are defined as AN2, is higher than the value entered to the "P123 Temperature 1 High Warning" parameter. It is just a warning message. Does not stop the motor.

**Possible Causes and required actions:** There may be a problem that causes the temperature to increase. Incorrect sensor may have been selected. Incorrect sensor type may have been selected. The value that is entered to the parameter may have been wrong for the application.

#### 1.6.2.14 Screw Temperature High Fault (Temp1Upper Alarm)



**Fault Definition:** Indicates that the value read by the Screw temperature sensor connected to terminals 7-8, which are defined as AN2, is higher than the value entered to the "P122 Temperature 1 High Alarm" parameter. It is a malfunction that stops the compressor rapidly.

**Possible Causes and required actions:** There may be a problem that causes the temperature to increase. Incorrect sensor may have been selected. Incorrect sensor type may have been selected. The value that is entered to the parameter may have been wrong for the application.

#### 1.6.2.15 Second Temperature High Warning (Temp2 Upper Warn)



**Warning Definition:** Indicates that the value read by the secondary temperature sensor connected to terminals 3-4, which are defined as AN4, is higher than the value entered to the "P135 Temperature 2 High Warn" parameter. It is just a warning message. Does not stop the motor.

**Possible Causes and required actions:** There may be a problem that causes the temperature to increase. Incorrect sensor may have been selected. Incorrect sensor type may have been selected. The value that is entered to the parameter may have been wrong for the application.



#### 1.6.2.16 Second Temperature High Fault (Temp2Upper Alarm)



**Fault Definition:** Indicates that the value read by the Screw temperature sensor connected to terminals 3-4, which are defined as AN4, is higher than the value entered to the "P134 Temperature 2 High Alarm" parameter. It is a malfunction that stops the compressor rapidly.

**Possible Causes and required actions:** There may be a problem that causes the temperature to increase. Incorrect sensor may have been selected. Incorrect sensor type may have been selected. The value that is entered to the parameter may have been wrong for the application.

#### 1.6.2.17 Screw Temperature Low Warning (Temp1 Down Warn)



**Warning Definition:** Indicates that the value read by the Screw temperature sensor connected to terminals 7-8, which are defined as AN2, is lower than the value entered to the "P125 Temperature 1 Low Warn" parameter. It is just a warning message. Does not stop the motor.

**Possible Causes and required actions:** Incorrect sensor may have been selected. Incorrect sensor type may have been selected. The value that is entered to the parameter may have been wrong for the application.

#### 1.6.2.18 Screw Temperature Low Fault (Temp1 Down Alarm)



**Fault Definition:** Indicates that the value read by the Screw temperature sensor connected to terminals 7-8, which are defined as AN2, is lower than the value entered to the "P124 Temperature 1 Low Alarm" parameter. It is a malfunction that stops the compressor rapidly.

**Possible Causes and required actions:** Incorrect sensor may have been selected. Incorrect sensor type may have been selected. The value that is entered to the parameter may have been wrong for the application.

#### 1.6.2.19 Second Temperature Low Warning (Temp2 Down Warn)



**Warning Definition:** Indicates that the value read by the secondary temperature sensor connected to terminals 3-4, which are defined as AN4, is lower than the value entered to the "P137 Temperature 2 Low Warn" parameter. It is just a warning message. Does not stop the motor.

**Possible Causes and required actions:** There may be a problem that causes the temperature to increase. Incorrect sensor may have been selected. Incorrect sensor type may have been selected. The value that is entered to the parameter may have been wrong for the application.

#### 1.6.2.20 Second Temperature Low Fault (Temp2 Down Alarm)



**Fault Definition:** Indicates that the value read by the Screw temperature sensor connected to terminals 3-4, which are defined as AN4, is lower than the value entered to the "P136 Temperature 2 Low Alarm" parameter. It is a malfunction that stops the compressor rapidly.

**Possible Causes and required actions:** There may be a problem that causes the temperature to increase. Incorrect sensor may have been selected. Incorrect sensor type may have been selected. The value that is entered to the parameter may have been wrong for the application.

#### 1.6.2.21 R Phase Voltage High Warning (Vr High Warn)



**Warning Definition:** Indicates that the R Phase Voltage connected to the terminal "25", which is defined as "R", is higher than the value entered to the "P146 Mains Voltage High Warn" parameter. It is just a warning message. Does not stop the motor.

**Possible Causes and required actions:** There may be a voltage rise in the system. The value that is entered to the parameter may have been wrong for the application.

#### 1.6.2.22 R Phase Voltage High Fault (Vr High Alarm)



**Fault Definition:** Indicates that the R Phase Voltage connected to the terminal "25", which is defined as "R", is higher than the value entered to the "P145 Mains Voltage High Alarm" parameter. It is a malfunction that stops the compressor rapidly.

**Possible Causes and required actions:** There may be a voltage rise in the system. The value that is entered to the parameter may have been wrong for the application.

#### 1.6.2.23 S Phase Voltage High Warning (Vs High Warn)



**Warning Definition:** Indicates that the S Phase Voltage connected to the terminal "24", which is defined as "S", is higher than the value entered to the "P146 Mains Voltage High Warn" parameter. It is just a warning message. Does not stop the motor.

**Possible Causes and required actions:** There may be a voltage rise in the system. The value that is entered to the parameter may have been wrong for the application.

#### 1.6.2.24 S Phase Voltage High Fault (Vs High Alarm)



**Fault Definition:** Indicates that the S Phase Voltage connected to the terminal "24", which is defined as "S", is higher than the value entered to the "P145 Mains Voltage High Alarm" parameter. It is a malfunction that stops the compressor rapidly.

**Possible Causes and required actions:** There may be a voltage rise in the system. The value that is entered to the parameter may have been wrong for the application.

#### 1.6.2.25 T Phase Voltage High Warning (Vt High Warn)



**Warning Definition:** Indicates that the T Phase Voltage connected to the terminal “23”, which is defined as “T”, is higher than the value entered to the “P146 Mains Voltage High Warn” parameter. It is just a warning message. Does not stop the motor.

**Possible Causes and required actions:** There may be a voltage rise in the system. The value that is entered to the parameter may have been wrong for the application.

#### 1.6.2.26 T Phase Voltage High Fault (Vt High Alarm)



**Fault Definition:** Indicates that the T Phase Voltage connected to the terminal “23”, which is defined as “T”, is higher than the value entered to the “P145 Mains Voltage High Alarm” parameter. It is a malfunction that stops the compressor rapidly.

**Possible Causes and required actions:** There may be a voltage rise in the system. The value that is entered to the parameter may have been wrong for the application.

#### 1.6.2.27 R Phase Voltage Low Warning (Vr Low Warn)



**Warning Definition:** Indicates that the R Phase Voltage connected to the terminal “25”, which is defined as “R”, is lower than the value entered to the “P144 Mains Voltage Low Warn” parameter. It is just a warning message. Does not stop the motor.

**Possible Causes and required actions:** There may be a voltage drop in the system. The value that is entered to the parameter may have been wrong for the application. If the mains voltage is not connected to the device, the parameter "P153 Mains Failure Control" should be set to "0". If the connection is made, make sure that the "P151 Mains Connection Type" parameter is set correctly.

#### 1.6.2.28 R Phase Voltage Low Fault (Vr Low Alarm)



**Fault Definition:** Indicates that the R Phase Voltage connected to the terminal “25”, which is defined as “R”, is lower than the value entered to the “P143 Mains Voltage Low Alarm” parameter. It is a malfunction that stops the compressor rapidly.

**Possible Causes and required actions:** There may be a voltage drop in the system. The value that is entered to the parameter may have been wrong for the application. If the mains voltage is not connected to the device, the parameter "P153 Mains Failure Control" should be set to "0". If the connection is made, make sure that the "P151 Mains Connection Type" parameter is set correctly.

#### 1.6.2.29 S Phase Voltage Low Warning (Vs Low Warn)



**Warning Definition:** Indicates that the S Phase Voltage connected to the terminal “24”, which is defined as “S”, is lower than the value entered to the “P144 Mains Voltage Low Warn” parameter. It is just a warning message. Does not stop the motor.

**Possible Causes and required actions:** There may be a voltage drop in the system. The value that is entered to the parameter may have been wrong for the application. If the mains voltage is not connected to the device, the parameter "P153 Mains Failure Control" should be set to "0". If the connection is made, make sure that the "P151 Mains Connection Type" parameter is set correctly.

#### 1.6.2.30 S Phase Voltage Low Fault (Vs Low Alarm)



**Fault Definition:** Indicates that the S Phase Voltage connected to the terminal “24”, which is defined as “S”, is lower than the value entered to the “P143 Mains Voltage Low Alarm” parameter. It is a malfunction that stops the compressor rapidly.

**Possible Causes and required actions:** There may be a voltage drop in the system. The value that is entered to the parameter may have been wrong for the application. If the mains voltage is not connected to the device, the parameter "P153 Mains Failure Control" should be set to "0". If the connection is made, make sure that the "P151 Mains Connection Type" parameter is set correctly.

#### 1.6.2.31 T Phase Voltage Low Warning (Vt Low Warn)



**Warning Definition:** Indicates that the T Phase Voltage connected to the terminal “23”, which is defined as “T”, is lower than the value entered to the “P144 Mains Voltage Low Warn” parameter. It is just a warning message. Does not stop the motor.

**Possible Causes and required actions:** There may be a voltage drop in the system. The value that is entered to the parameter may have been wrong for the application. If the mains voltage is not connected to the device, the parameter "P153 Mains Failure Control" should be set to "0". If the connection is made, make sure that the "P151 Mains Connection Type" parameter is set correctly.

#### 1.6.2.32 T Phase Voltage Low Fault (Vt Low Alarm)



**Fault Definition:** Indicates that the T Phase Voltage connected to the terminal “23”, which is defined as “T”, is lower than the value entered to the “P143 Mains Voltage Low Alarm” parameter. It is a malfunction that stops the compressor rapidly.

**Possible Causes and required actions:** There may be a voltage drop in the system. The value that is entered to the parameter may have been wrong for the application. If the mains voltage is not connected to the device, the parameter "P153 Mains Failure Control" should be set to "0". If the connection is made, make sure that the "P151 Mains Connection Type" parameter is set correctly.

#### 1.6.2.33 High Frequency Warning (Freq High Warn)



**Warning Definition:** Indicates that the 3 Phase Frequency connected to the terminals “25-24-23”, which are defined as “R-S-T” is higher than the value entered to the “P150 Mains Frequency High Warn” parameter. It is just a warning message. Does not stop the motor.

**Possible Causes and required actions:** There may be an increase in the frequency of mains voltage. The value that is entered to the parameter may have been wrong for the application.

#### 1.6.2.34 High Frequency Fault (Freq High Alarm)



**Fault Definition:** Indicates that the 3 Phase Frequency connected to the terminals “25-24-23”, which are defined as “R-S-T” is higher than the value entered to the “P149 Mains Frequency High Alarm” parameter. It is a malfunction that stops the compressor rapidly.

**Possible Causes and required actions:** There may be an increase in the frequency of mains voltage. The value that is entered to the parameter may have been wrong for the application.

#### 1.6.2.35 Low Frequency Warning (Freq Low Warn)



**Warning Definition:** Indicates that the 3 Phase Frequency connected to the terminals “25-24-23”, which are defined as “R-S-T” is lower than the value entered to the “P148 Mains Frequency Low Warning” parameter. It is just a warning message. Does not stop the motor.

**Possible Causes and required actions:** There may be a decrease in the frequency of mains voltage. The value that is entered to the parameter may have been wrong for the application.

#### 1.6.2.36 Low Frequency Fault (Freq Low Alarm)



**Fault Definition:** Indicates that the 3 Phase Frequency connected to the terminals “25-24-23”, which are defined as “R-S-T” is lower than the value entered to the “P147 Mains Frequency Low Alarm” parameter. It is a malfunction that stops the compressor rapidly.

**Possible Causes and required actions:** There may be a decrease in the frequency of mains voltage. The value that is entered to the parameter may have been wrong for the application.

#### 1.6.2.37 Phase Sequence / Unbalance Error (Phase Unbalance)



**Fault Definition:** Indicates that the sequence of 3 Phase Frequency connected to the terminals “25-24-23”, which are defined as “R-S-T”, is not suitable for the device or is unbalanced. It is a malfunction that stops the compressor rapidly.

**Possible Causes and required actions:** There may be a problem with the mains connections. The value of the "P142 Unbalance%" parameter may not be suitable for the system. If the phase sequence / unbalance control is not needed, the parameter "P152 Phase Sequence Protect" must be set as "0" (passive).

1.6.3 Functional Faults

1.6.3.1. Service Time (Service Level 1, 2, 3, 4, 5)

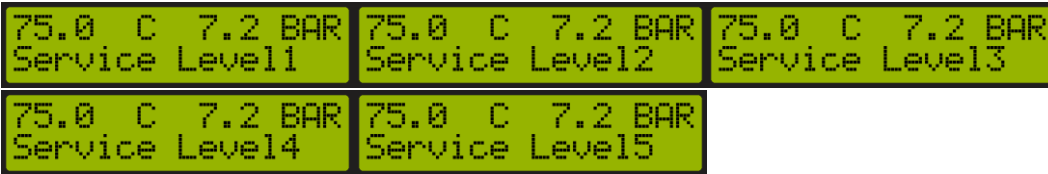

	Time remaining for service - Hours	Event		Occurrence Period - Hours
Service Level 1	[100 : 0)	Warning	Can be reset	100
Service Level 2	[0 : -100)	Error	Can be reset; press and hold ESC for 10 sec	100
Service Level 3	[-100 : -200)	Error	Can be reset; press and hold ESC for 10 sec	20
Service Level 4	[-200 : -300)	Error	Can be reset; press and hold ESC for 10 sec	10
Service Level 5	[-300 : ...)	Error	Cannot be reset; Service times should be refreshed	---

1.6.3.2. Maximum Start Per Hour error (Maximum Startup)



**Fault Definition:** Indicates that the compressor is stopped and restarted within a period that is longer than the amount set to the "P158 Maximum Startup" parameter. It is a malfunction that stops the compressor rapidly.

**Possible Causes and required actions:** Stopping and running for a period that is longer than the specified time may indicate a problem in the system. The value of the relevant parameter may not be suitable for the system.

1.6.3.3 Power fault automatic run (Power Intrpt)



**Warning Definition:** Power cut and come back while the compressor is running, the device will restart the compressor at the end of the time set to the "P27 Power Cut Restart Delay" parameter. If automatic restart is not required, "0" value is entered to the relevant parameter.

2. Parameters and parameter descriptions

2.1. Parameter List

Cat.	Pno	Parameter Definition	Min	Max	Def	Birim	Sev
Pressure	2	Idle Pressure	0,0	16,0	7,5	Bar	1
Pressure	3	Onload Pressure	0,0	16,0	6,0	Bar	1
Pressure	4	Line Alarm Value	0,0	16,0	8,5	Bar	2
Pressure	5	Line Warning Value	0,0	16,0	8,0	Bar	1
Pressure	6	Screw Sensor Control	0,0	1,0	1,0		2
Pressure	7	Minimum Screw Pressure	0,0	16,0	0,5	Bar	1

Pressure	8	Screw Pressure Alarm	0,0	16,0	8,6	Bar	2
Pressure	9	Screw Pressure Warning	0,0	16,0	8,1	Bar	1
Pressure	10	Pressure Unit	0,0	1,0	0,0		1
Pressure	11	Delta Pressure Alarm	0,0	16,0	2,4	Bar	1
Pressure	12	Delta Pressure Warning	0,0	16,0	2,0	Bar	1
Pressure	13	Sufficiency Pressure	0,0	16,0	4,8	Bar	1
Pressure	14	Standard Pressure Value Load	0,0	16,0	7,5	Bar	2
Timing	21	Start Delay	2,0	60,0	5,0	sec	1
Timing	22	Stopping Time	0,0	180,0	20,0	sec	1
Timing	23	Air Discharge Time	0,0	60,0	10,0	sec	1
Timing	24	Idle Working Time	0,0	300,0	10,0	sec	1
Timing	25	Pass Again Onload Time	0,0	60,0	5,0	sec	1
Timing	26	Auto Waiting Delay	0,0	1200,0	180,0	sec	1
Timing	27	Power Cut Restart Delay	0,0	60,0	5,0	sec	1
Timing	28	Star Duration Time	1,0	30,0	5,0	sec	2
Timing	29	Main Contactor Delay	0,0	100,0	30,0	msec	3
Timing	30	Triangle Transfer Time	0,0	100,0	30,0	msec	3
Timing	31	Preheat Onload Time	0,0	60,0	10,0	sec	1
Timing	32	Preheat Idle Time	1,0	120,0	15,0	sec	1
Timing	33	Line Pressure Alarm Delay	0,0	30,0	3,0	sec	1
Timing	34	Screw Pressure Alarm Delay	0,0	30,0	3,0	sec	1
Timing	35	Delta Pressure Alarm Delay	0,0	30,0	3,0	sec	1
Timing	36	Fan Maksimum Working Time	0,0	1200,0	20,0	sec	1
Timing	37	Dryer Duration	0,0	60,0	50,0	min	1
Timing	38	Sufficiency Delay	0,0	600,0	300,0	sec	1
Timing	39	Horn Duration	10,0	999,0	60,0	sec	1
Inputs	44	Function	0	16	1		2
Inputs	45	Delay	0	30	0	sec	2
Inputs	46	Contactor Type	0	1	0		2
Inputs	48	Function	0	16	5		2
Inputs	49	Delay	0	30	3	sec	2
Inputs	50	Contactor Type	0	1	0		2
Inputs	52	Function	0	16	2		2
Inputs	53	Delay	0	30	3	sec	2
Inputs	54	Contactor Type	0	1	0		2
Inputs	56	Function	0	16	4		2
Inputs	57	Delay	0	30	1	sec	2
Inputs	58	Contactor Type	0	1	0		2
Inputs	60	Function	0	16	12		2
Inputs	61	Delay	0	30	3	sec	2
Inputs	62	Contactor Type	0	1	0		2
Inputs	64	Function	0	16	13		2
Inputs	65	Delay	0	30	3	sec	2
Inputs	66	Contactor Type	0	1	0		2
Inputs	68	Function	0	16	0		2
Inputs	69	Delay	0	30	0	sec	2
Inputs	70	Contactor Type	0	1	0		2
Inputs	72	Function	0	16	6		2
Inputs	73	Delay	0	30	0	sec	2
Inputs	74	Contactor Type	0	1	0		2

Output	92	Function	0	28	0		2
Output	93	Delay	0	30	0	sec	2
Output	94	Contactora Type	0	1	0		2
Output	96	Function	0	28	8		2
Output	97	Delay	0	30	0	sec	2
Output	98	Contactora Type	0	1	0		2
Output	100	Function	0	28	4		2
Output	101	Delay	0	30	0	sec	2
Output	102	Contactora Type	0	1	0		2
Output	104	Function	0	28	3		2
Output	105	Delay	0	30	0	sec	2
Output	106	Contactora Type	0	1	0		2
Output	108	Function	0	28	2		2
Output	109	Delay	0	30	0	sec	2
Output	110	Contactora Type	0	1	0		2
Output	112	Function	0	28	1		2
Output	113	Delay	0	30	0	sec	2
Output	114	Contactora Type	0	1	0		2
Maintenance	140	General Maintenance	200	30000	2500	h	3
Maintenance	141	Roller Maintenance	200	30000	20000	h	3
Maintenance	142	Oil Change Maintenance	200	30000	5000	h	3
Maintenance	143	Air Filter Maintenance	200	30000	5000	h	3
Maintenance	144	Oil Filter Maintenance	200	30000	2500	h	3
Maintenance	145	Seperator Filter Maintenance	200	30000	5000	h	3
Maintenance	148	Service Alarm Activation	0	1	0		3
Maintenance	149	Maintenance Reset	0	6	0		2
Calibration	150		-9.000	9.000	0		3
Calibration	151		-9.000	9.000	1.000		3
Calibration	153		-9.000	9.000	0		3
Calibration	154		-9.000	9.000	1.000		3
Calibration	156		-9.000	9.000	0		3
Calibration	157		-9.000	9.000	1.000		3
Calibration	158		-9.000	9.000	0		3
Calibration	159		-9.000	9.000	1.000		3
Calibration	160		-9.000	9.000	0		3
Calibration	161		-9.000	9.000	1.000		3
Calibration	162		-9.000	9.000	0		3
Calibration	163		-9.000	9.000	1.000		3
Temperature	172	Temperature 1 High Alarm	-200,0	200,0	100,0	C	1
Temperature	173	Temperature 1 High Warning	-200,0	200,0	90,0	C	1
Temperature	174	Temperature 1 Low Alarm	-200,0	200,0	-20,0	C	1
Temperature	175	Temperature 1 Low Warn	-200,0	200,0	-10,0	C	1
Temperature	176	Preheat Limit	-200,0	200,0	10,0	C	1
Temperature	177	Temperature 1 SensorType	0	2	0		2
Temperature	178	Temperature Unit	0	1	0		1
Temperature	179	Fan Start	-200,0	200,0	80,0	C	1
Temperature	180	Fan Stop	-200,0	200,0	60,0	C	1
Temperature	181	Dryer Start Temperature	-200,0	200,0	15,0	C	1
Temperature	182	Dryer Stop Temperature	-200,0	200,0	5,0	C	1



Temperature	184	Temperature 2 High Alarm	-200,0	200,0	100,0	C	1
Temperature	185	Temperature 2 High Warn	-200,0	200,0	90,0	C	1
Temperature	186	Temperature 2 Low Alarm	-200,0	200,0	-20,0	C	1
Temperature	187	Temperature 2 Low Warn	-200,0	200,0	-10,0	C	1
Temperature	188	Temperature 2 Sensor Type	0	2	0		2
Temperature	189	Temperature 2 Sensor Mode	0	2	0		2
Temperature	190	Press.Comp.Temp.	-200,0	200,0	0,0	C	2
Temperature	191	Oil Freeze Prevent	-200,0	10,0	-99,9	C	2
Mains	200	Unbalance	0	100	20		2
Mains	201	Mains Voltage Low Alarm	0	600	310	V	2
Mains	202	Mains Voltage Low Warn	0	600	330	V	1
Mains	203	Mains Voltage High Alarm	0	600	466	V	2
Mains	204	Mains Voltage High Warn	0	600	450	V	1
Mains	205	Mains Frequency Low Alarm	0,0	80,0	45,0	Hz	2
Mains	206	Mains Frequency Low Warn	0,0	80,0	47,0	Hz	1
Mains	207	Mains Frequency High Alarm	0,0	80,0	55,0	Hz	2
Mains	208	Mains Frequency High Warn	0,0	80,0	53,0	Hz	1
Mains	209	Mains Connection Type	0	2	2		3
Mains	210	PhaseSequence Protect	0	1	1		2
Mains	211	Mains Failure Control	0	1	0		2
General Set.	220	Factory Password	0	9999	1923		3
General Set.	221	Service Password	0	9999	1922		2
General Set.	222	User Password	0	9999	1934		1
General Set.	224	Maximum Startup	2	9999	10		1
General Set.	225	Compressor Start Source	0	4	0		1
General Set.	226	Working Mode	0	1	1		1
General Set.	227	Idle Time S/D	0	1	0		1
General Set.	228	Horn Mode	0	1	0		1
General Set.	229	Pressure Loss Prevent	0	2	0		2
General Set.	230	Parameters Save	0	2	0		1
General Set.	232	Language Selection	0	2	0		1
General Set.	233	Reload Factory Value	0	2	0		3
General Set.	234	Reset Alarm History	0	1	0		3
General Set.	235	Reset Motor Time	0	1	0		3
General Set.	236	Menu Logout Time	1	30	3	min	1
General Set.	237	Menu Logout	0	1	0		2
General Set.	238	Dynamic Password	0	10	0		3

## 2.2. Parameter descriptions

### 2.2.1 Pressure Parameters

All parameters related to pressure are under this heading.

*P002: Idle Pressure (Idle Pressure):*

When the line pressure reaches/exceeds the value specified with this parameter while the device is running at load, the device switches to idle operation.

*P003: Load Pressure (Onload Pressure):*

In automatic operation mode, if the line pressure reaches or drops below the value specified with this parameter while the compressor is in stop or idle mode, the device will start to run and switch to load.

*P004: Discharge Pressure Alarm Level (Line Alarm Value):*

When the supply pressure reaches the value specified here, the device switches to fault mode at the end of the time entered to the "P033 Line Pressure Alarm Delay" parameter. The protection function can be cancelled by setting the related parameter to "0".

*P005: Discharge Pressure Warning Level (Line Warn Value):*

When the supply pressure exceeds the value specified here, at the end of the time entered to the "P033 Line Pressure Alarm Delay" parameter, the device displays the relevant warning on the screen.

*P006: Screw Sensor Enable (Screw Sensor):*

Used to activate the use of screw pressure sensor.

*P007: Low Level Screw Pressure (Min Screw Press.):*

If the measured screw pressure is equal to or higher than the value entered to this parameter, when the run command is received when the device is in stop mode, the compressor is not started and the system waits for the pressure value to decrease. When the screw pressure drops below this value, the running process continues.

*P008: Screw Pressure Fail Alarm (ScrewPress Alarm):*

When the screw pressure reaches the value specified here, the device switches to fault mode at the end of the time entered to the "P034 Screw Pressure Alarm Delay" parameter. The protection function can be cancelled by setting the related parameter to "0".

*P009: Screw Pressure Warning Alarm (ScrewPress Warn):*

When the supply pressure exceeds the value specified here, at the end of the time entered to the "P034 Screw Pressure Alarm Delay" parameter, the device displays the relevant warning on the screen.

*P010: Pressure Unit (Pressure Unit):*

Determines the pressure unit that the device measures in, displays on the screen and checks. Can be selected as BAR or PSI.

*P011: Pressure Difference Fail Alarm (DeltaPress Alarm):*

If the difference between the screw pressure and the line pressure is above this value, the device switches to fault mode with the message "DeltaPress Alarm" at the end of the "P035 Delta Pressure Alarm Delay" period.

*P012: Pressure Difference Warning Alarm (DeltaPress Warn):*

If the difference between the screw pressure and the line pressure is above this value, the message "DeltaPress Warn" is displayed on the screen.

*P013: Difference Pressure Limit Value (SufficiencyPress):*

When the screw pressure value reaches the value entered to this parameter, the pressure difference and warning functions are activated. Relevant controls are not made at pressure values below the value entered to these parameters.

*P014: Standard Pressure Load (Stand.Press Load):*

Used to quickly load standard pressure values. The value entered to this parameter, the automatically changing parameters and the formulas of the changing values are given in the table below.

<b>Affected Parameter</b>	<b>Affection Status</b>
P002: Switch to Idle Pressure (Switch to Idle Press.):	= P014
P003: Switch to Load Pressure (Switch to Load Press.):	= P014 – 1.5 BAR
P004: Line Pressure Fault Value (Line Press Fault):	= P014 + 1.0 BAR
P005: Line Pressure Warning Value (Line Press Warning):	= P014 + 0.5 BAR
P008: Screw Pressure Fault Value (Screw Press Fault):	= P014 + 1.1 BAR
P009: Screw Pressure Warning Value (Screw Press Warning):	= P014 + 0.6 BAR

2.2.2 Timing Parameters

All timing parameters that can be adjusted with the device are under this heading.

*P021: Start Delay Time (Start Delay):*

When the device receives a run command, it waits for the time entered to this parameter. The time remaining is displayed on the right side of the screen.

*P022: Stopping Time (Stopping Time):*

When the device receives a stop command, it waits for the time entered to this parameter. The time remaining is displayed on the right side of the screen.

*P023: Air Discharge Time Duration (Air Discharge):*

The expected time for the air pressure of the screw to drop after the compressor stops. During this time, the compressor cannot be started.

*P024: Idle Working Time Duration (Idle Working):*

Specifies the idle run time before switching to the load when the device receives a run command.

*P025: Reload Time Delay (PassAgain Onload):*

During the idle run process that starts after the compressor running on load switches to idle, when the supply pressure drops below the value entered to the "P003 Onload Pressure" parameter, the time specified with this parameter is counted and then the device switches back to load.

*P026: "Auto Waiting Delay(Auto Waiting):*

The time to wait for the compressor to stop after reaching the switch to idle pressure is set with this parameter. During this time, the compressor runs in idle mode. This parameter works on the condition that the value entered to the "P160 Working Mode" parameter is selected as "Automatic".

*P027: Power Fail Restart Delay Time (Power Cut):*

In case of power faults that occur while the compressor is running, after the power is on again, the device switches to run mode at the end of the time set with this parameter. By entering "0" value to the relevant parameter, the automatic run function at power fault is cancelled.

*P028: Star Feed Operation Time (Star Duration):*

In the motor starting stage, running duration of star contactor of motor is adjusted with this parameter.

*P029: Main Contactor Trigger Delay (Main Contactor):*

After the star contactor is triggered, the main output is activated at the end of the time value entered to this parameter.

*P030: Start-Delta Transfer Time (Delta Transfer):*

After the star contactor is deactivated, the delta contactor output is activated at the end of the time value entered to this parameter.

*P031: Pre-Heat On-Load Time (Preheat Onload):*

Indicates the time to stay on load in the preheat running mode.

*P032: Pre-Heat Off-Load Time (Preheat Idle):*

Indicates the time to stay IDLE in the preheat running mode.

*P033 Discharge Pressure Fail Alarm Delay (Line Press Alarm):*

The expected delay time for line pressure alarm error.

*P034: Screw Pressure Fail Alarm Delay (ScrewPress Alarm):*

The expected delay time for screw pressure alarm error.

*P035: Pressure Difference Fail Alarm Delay (DeltaPress Alarm):*

The expected delay time for pressure difference alarm error.

*P036: Fan Maximum Operation Time (Fan Working Time):*

If the compressor stops while the fan running condition continues, the fan continues to run within this period. At the end of the period, the fan is stopped regardless of the temperature conditions.

*P037: Dryer Operation Time (Dryer Duration):*

The duration of the dryer function. See "7.10 Application note Dryer Functions,"

*P038: Pressure Difference Alarm Delay Time (Sufficiency):*

The delay time for the qualification pressure error set with the "P013 Sufficiency Pressure" parameter.

*P039: Horn Duration (Horn Duration):*

Indicates the blowing time of the horn when an alarm occurs. At the end of this period, the horn is silenced.

### 2.2.3 Digital Input Parameters

*Functions That Can Be Assigned to Inputs:*

The functions that can be assigned to the inputs and their explanations are as follows.

**None:** No function is assigned to the related digital input. If no connection has been made, it is recommended to set it as "None".

**EmerStp:** Emergency stop input. When this function is assigned and the input is active, the compressor is unconditionally stopped.

**Seperat.:** This is separator filter blocked sensor input. When this function is assigned and the input is active, the compressor is unconditionally stopped.

**OilPres.:** This is the oil pressure error input. When this function is assigned and the input is active, the compressor is unconditionally stopped.

**PhaseSeq:** This is the externally connected phase sequence relay error input. When this function is assigned and the input is active, the compressor is unconditionally stopped.

**MThermic:** This is the error input for the motor thermic protection relay. When this function is assigned and the input is active, the compressor is unconditionally stopped.

**FThermic:** This is the error input for the fan thermic protection relay. When this function is assigned and the input is active, the compressor is unconditionally stopped.

**RemoteSS:** This is the remote start input. See "Application note Remote start".

**StartBtn:** This is the function used to control the compressor from a remote point with the start button. When this function is assigned and the input is active, the device confirms that the start button was pressed.

**StopBtn:** This is the function used to control the compressor from a remote point with the stop button. When this function is assigned and the input is active, the device confirms that the stop button was pressed.

**RemoteLD:** Used to control the load valve remotely. See "Application note Remote start".

**PTC:** This function works only on DI7 input. When this function is assigned to the relevant input, the Motor PTC must be connected to DI7 input as in the diagram below.

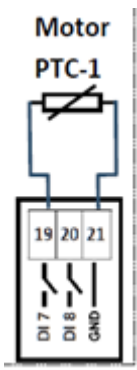

**Aux1 Alarm:** The first backup alarm input. When this function is assigned and the input is active, the compressor is unconditionally stopped.

**Aux2 Alarm:** The second backup alarm input. When this function is assigned and the input is active, the compressor is unconditionally stopped.

**Ln Switch:** This is the function to be used for line pressure in running with pressure switch. See "Application note Running with pressure switch".

**Sc Switch:** This is the function to be used for screw pressure in running with pressure switch. See "Application note Running with pressure switch".

**AlarmReset:** Remote alarm clearing function. When this function is assigned and the input is active, if the alarm in the device is resolved, the fault is cleared.

**Door Open:** Compressor panel cover control function. When this function is assigned and the input is active, the compressor is unconditionally stopped.

*P044: Input Function 1:*

The Function parameter that will be assigned to the input on the device's terminal 12, which is defined as DI1. See "Functions That Can Be Assigned to Inputs", Default function is "EmerStp".

*P045: Input Delay 1:*

After the relevant input is active, at the end of the time value entered to this parameter, the device takes the input as active.

*P046: Input Contact Type 1:*

The contact type of the relevant input, can be selected as NO (normally open) or NC normally closed.

*P048: Input Function 2:*

The Function parameter that will be assigned to the input on the device's terminal 13, which is defined as DI2. See "Functions That Can Be Assigned to Inputs", Default function is "MThermic".

*P049: Input Delay 2:*

After the relevant input is active, at the end of the time value entered to this parameter, the device takes the input as active.

*P050: Input Contact Type 2:*

The contact type of the relevant input, can be selected as NO (normally open) or NC normally closed.

*P052: Input Function 3:*

The Function parameter that will be assigned to the input on the device's terminal 14, which is defined as DI3. See "Functions That Can Be Assigned to Inputs", Default function is "Separate."

*P053: Input Delay 3:*

After the relevant input is active, at the end of the time value entered to this parameter, the device takes the input as active.

*P054: Input Contact Type 3:*

The contact type of the relevant input, can be selected as NO (normally open) or NC normally closed.

*P056: Input Function 4:*

The Function parameter that will be assigned to the input on the device's terminal 16, which is defined as DI4. See "Functions That Can Be Assigned to Inputs", Default function is "PhaseSeq".

*P057: Input Delay 4:*

After the relevant input is active, at the end of the time value entered to this parameter, the device takes the input as active.

*P058: Input Contact Type 4:*

The contact type of the relevant input, can be selected as NO (normally open) or NC normally closed.

*P060: Input Function 5:*

The Function parameter that will be assigned to the input on the device's terminal 17, which is defined as DI5. See "Functions That Can Be Assigned to Inputs", Default function is "OilPres."

*P061: Input Delay 5:*

After the relevant input is active, at the end of the time value entered to this parameter, the device takes the input as active.

*P062: Input Contact Type 5:*

The contact type of the relevant input, can be selected as NO (normally open) or NC normally closed.

*P064: Input Function 6:*

The Function parameter that will be assigned to the input on the device's terminal 18, which is defined as DI6. See "Functions That Can Be Assigned to Inputs", Default function is "Aux1 Alarm".

*P065: Input Delay 6:*

After the relevant input is active, at the end of the time value entered to this parameter, the device takes the input as active.

*P066: Input Contact Type 6:*

The contact type of the relevant input, can be selected as NO (normally open) or NC normally closed.

*P068: Input Function 7:*

The Function parameter that will be assigned to the input on the device's terminal 19, which is defined as DI7. See "Functions That Can Be Assigned to Inputs" Default function "None".

*P069: Input Delay 7:*

After the relevant input is active, at the end of the time value entered to this parameter, the device takes the input as active.

*P070: Input Contact Type 7:*

The contact type of the relevant input, can be selected as NO (normally open) or NC normally closed.

*P072: Input Function 8:*

The Function parameter that will be assigned to the input on the device's terminal 20, which is defined as DI8. See "Functions That Can Be Assigned to Inputs", Default function is "FThermic".

*P073: Input Delay 8:*

After the relevant input is active, at the end of the time value entered to this parameter, the device takes the input as active.

*P074: Input Contact Type 8:*

The contact type of the relevant input, can be selected as NO (normally open) or NC normally closed.

## 2.2.4 Digital Output Parameters

*Functions That Can Be Assigned to Outputs:*

The functions that can be assigned to the outputs and their explanations are as follows.

**None:** No function is assigned to the related digital output. If no connection has been made, it is recommended to set it as "None".

**Main Con.:** The output function that the Main Contactor will be connected.

**Star Con.:** The output function that Star Contactor will be connected.

**DeltaCon.:** The output function that the delta contactor will be connected.

**LoadValve:** The output function that the load valve will be connected.

**Alarm:** In case of any fault, this output becomes active.

**Warning:** In case of any warning, this output becomes active.

**Alarm+Warn:** In case of any fault or warning, this output becomes active.

**Fan:** The output function where the Fan Contactor will be connected.

**OnLoad:** The output is active when the compressor is running and the solenoid valve is active.

**Idle:** The output is active when the compressor is running and the solenoid valve is passive.

**Running:** When the compressor motor is running, this output is active.

**Stopping:** When the compressor motor stops, this output is active.

**Horn:** The output to which horn, siren or similar warning equipment will be connected.

**Dryer-Z:** This is an output for the dryer, which is activated when the compressor starts working (pre-heat, off-load and on-load). When the compressor stops working, this output will continue to remain active for the duration set in P037, before being deactivated.

**Dryer-S:** This is an output for the dryer, which is activated based on the temperature measured by the Temperature-2 sensor and the range defined in P181 and P182. When the compressor is working (pre-heat, off-load and on-load), this output will be activated when the temperature measured by the Temperature-2 sensor goes above the value set in P181, and deactivated when it reaches the value set in P182.

When the compressor transitions to the auto-wait, air-discharge or wait states, if the temperature has reached the value set in P182, this output is deactivated; if not, the dryer output will remain active for the duration set in P037 after the compressor has stopped.

**RSS Active:** This output is activated only when the starting source is selected as Modbus, Digital input or Modbus + Digital input.

**T.LowAlarm:** This output is activated when the screw oil temperature drops below the value entered to the "P124 Temperature 1 Low Alarm " parameter.

**T.Up Alarm:** This output is activated when the screw oil temperature rises above the value entered to the "P122 Temperature 1 High Alarm " parameter.

**T.Low Warn:** This output is activated when the screw oil temperature drops below the value entered to the "P125 Temperature 1 Low Warn" parameter.

**T.Up Warn:** This output is activated when the screw oil temperature exceeds the value entered to the "P123 Temperature 1 High Warning" parameter.

**P1 Alarm:** Activated when an error occurs in the sensor reading the line pressure.

**P2 Alarm:** Activated when an error occurs in the sensor reading the screw pressure.

**T1 Alarm:** Activated when an error occurs in the sensor reading the screw temperature.

**T2 Alarm:** Activated when an error occurs in the sensor reading the second temperature.

**T2 L.Alarm:** The output is activated when the temperature measured by the sensor connected to the second temperature input drops below the value entered to the "P136 Temperature 2 Low Alarm " parameter.

**T2 H.Alarm:** The output is activated when the temperature measured by the sensor connected to the second temperature input exceeds the value entered to the "P134 Temperature 2 High Alarm" parameter.

**T2 L.Warn:** The output is activated when the temperature measured by the sensor connected to the second temperature input drops below the value entered to the "P137 Temperature 2 Low Warn " parameter.

**T2 H.Warn:** The output is activated when the temperature measured by the sensor connected to the second temperature input exceeds the value entered to the " Temperature 2 High Warn " parameter.

#### *P092: Output Function1:*

The function parameter of the device to be assigned for the output on the terminals 35-37, which are defined as OUT1. See "Functions That Can Be Assigned to Outputs", Default function is "None".

#### *P093: Output Delay1:*

Related output becomes active at the end of the time value entered to this parameter.



*P094: Output Contact Type1:*

The contact type of the relevant output, can be selected as NO (normally open) or NC normally closed.

*P096: Output Function 2:*

The function parameter of the device to be assigned for the output on the terminals 35-36, which are defined as OUT2. See "Functions That Can Be Assigned to Outputs", Default function is "Fan"

*P097: Output Delay 2:*

Related output becomes active at the end of the time value entered to this parameter.

*P098: Contact Type 2:*

The contact type of the relevant output, can be selected as NO (normally open) or NC normally closed.

*P100: Output Function 3:*

The function parameter of the device to be assigned for the output on the terminals 33-34, which are defined as OUT3. See "Functions That Can Be Assigned to Outputs", Default function is "LoadValve"

*P101: Output Delay 3:*

Related output becomes active at the end of the time value entered to this parameter.

*P102: Contact Type 3:*

The contact type of the relevant output, can be selected as NO (normally open) or NC normally closed.

*P104: Output Function 4:*

The function parameter of the device to be assigned for the output on the terminals 31-32, which are defined as OUT4. See "Functions That Can Be Assigned to Outputs", Default function is "DeltaCon"

*P105: Output Delay 4:*

Related output becomes active at the end of the time value entered to this parameter.

*P106: Contact Type 4:*

The contact type of the relevant output, can be selected as NO (normally open) or NC normally closed.

*P108: Output Function 5:*

The function parameter of the device to be assigned for the output on the terminals 30-32, which are defined as OUT5. See "Functions That Can Be Assigned to Outputs", Default function is "StarCon"

*P109: Output Delay 5:*

Related output becomes active at the end of the time value entered to this parameter.

*P110: Contact Type 5:*

The contact type of the relevant output, can be selected as NO (normally open) or NC normally closed.

*P112: Output Function 6:*

The function parameter of the device to be assigned for the output on the terminals 29-32, which are defined as OUT6. See "Functions That Can Be Assigned to Outputs", Default function is "Main Con"

*P113: Output Delay 6:*

Related output becomes active at the end of the time value entered to this parameter.

*P114: Contact Type 6:*

The contact type of the relevant output, can be selected as NO (normally open) or NC normally closed.

### 2.2.5 Service Times Parameters

#### *P140 Overall Maintenance Time Set(General Maint.)*

The general service time is set with this parameter.

#### *P141 Bearing Maintenance Time Set(Roller Maint.):*

The bearing maintenance time is set with this parameter.

#### *P142 Oil Change Service Time Set(OilChange Maint.):*

The oil change time is set with this parameter.

#### *P143 Air Filter Service Time Set (AirFilter Maint.):*

The Service Air Filter Replacement time is set with this parameter.

#### *P144 Oil Filter Service Time Set(OilFilter Maint.):*

The oil filter replacement time is set with this parameter.

#### *P145 Separator Filter Service Time Set(SepFilter Maint.):*

The separator filter change time is set with this parameter.

#### *P148 Service Alarm Activation*

This parameter is set to "1" so that the compressor stops when the maintenance time.

#### *P149 Maintenance Time Reset (Maintaince Reset):*

This parameter is used to reset the service time. The service time desired to be reset is selected with this parameter.

### 2.2.6 Temperature Parameters

#### *P172 Temperature-1 High-Fail Alarm (Temp1 High Alarm)*

When the temperature measured by the screw temperature sensor connected to the terminals 7-8 of the device, which are defined as AN2, exceeds the value entered to this parameter, the device gives a "Temp1Upper Alarm" and stops the compressor.

#### *P173 Temperature-1 High-Warning Alarm (Temp1 High Warn)*

When the temperature measured by the screw temperature sensor connected to the terminals 7-8 of the device, which are defined as AN2, exceeds the value entered to this parameter, the device gives a "Temp1 Upper Warn".

#### *P174 Temperature-1 Low-Fail Alarm (Temp1 Low Alarm)*

When the temperature measured by the screw temperature sensor connected to the terminals 7-8 of the device, which are defined as AN2, drops below the value entered to this parameter, the device gives a "Temp1 Down Alarm" and stops the compressor.

#### *P175 Temperature-1 Low-Warning Alarm (Temp1 Low Warn)*

When the temperature measured by the screw temperature sensor connected to the terminals 7-8 of the device, which are defined as AN2, drops below the value entered to this parameter, the device gives a "Temp1 Down Warn".

#### *P176 Preheat Temperature Limit (Preheat Limit)*

If the temperature measured by the screw temperature sensor connected to terminals 7-8 of the device, which are defined as AN2, at the first start-up, is less than the value entered to this parameter, the device runs in preheating mode until the temperature exceeds this value. See "Application note Preheat"

#### *P177 Temperature-1 Sensor Type Select (Temp1 SensorType)*

Type of the screw temperature sensor connected to terminals 7-8 of the device, which are defined as AN2, is determined by this parameter.

#### *P178 Temperature Unit (Temperature Unit)*

The temperature measurement unit used by the device in display and control stages is set with this parameter.

#### *P179 Fan Start Temperature Level (Fan Start)*

If the function of one of the outputs of the device is set as "Fan", when the value measured by the screw temperature sensor connected to terminals 7-8, which are defined as AN2, is more than the value entered with this parameter, the relevant Fan output is activated until it reaches the stop temperature.

#### *P180 Fan Stop Temperature Level (Fan Stop)*

If the function of one of the outputs of the device is set as "Fan", when the value measured by the screw temperature sensor connected to terminals 7-8, which are defined as AN2, is less than the value entered with this parameter, the relevant Fan output is deactivated until it reaches the running temperature.

#### *P181 Dryer Start Temperature Level (Dryer Start)*

There are two dryer functions, Dryer-Z and Dryer-S, in the digital output functions. When the Dryer-S function is selected, the dryer signal output is generated according to this function. Refer to the "Digital Output Functions" section for further details.

#### *P182 Dryer Stop Temperature Level (Dryer Stop)*

There are two dryer functions, Dryer-Z and Dryer-S, in the digital output functions. When the Dryer-S function is selected, the dryer signal output is generated according to this function. Refer to the "Digital Output Functions" section for further details.

#### *P184 Temperature-2 High-Fail Alarm (Temp2 High Alarm)*

When the temperature measured by the second temperature sensor connected to the terminals 3-4 of the device, which are defined as AN4, exceeds the value entered to this parameter, the device gives a "Temp2Upper Alarm".

#### *P185 Temperature-2 High-Warning Alarm (Temp2 High Warn)*

When the temperature measured by the second temperature sensor connected to the terminals 3-4 of the device, which are defined as AN4, exceeds the value entered to this parameter, the device gives a "Temp2 Upper Warn".

#### *P186 Temperature-2 Low-Fail Alarm (Temp2 Low Alarm)*

When the temperature measured by the screw temperature sensor connected to the terminals 3-4 of the device, which are defined as AN4, drops below the value entered to this parameter, the device gives a "Temp2 Down Alarm" and stops the compressor.

#### *P187 Temperature-2 Low-Warning Alarm (Temp2 Low Warn)*

When the temperature measured by the screw temperature sensor connected to the terminals 3-4 of the device, which are defined as AN4, drops below the value entered to this parameter, the device gives a "Temp2 Down Warn".

#### *P188 Temperature-2 Sensor Type Select (Temp2 SensorType)*

The type of the second temperature sensor connected to the terminals 3-4, which are defined as AN4, is determined by this parameter.

#### *P189 Temperature-2 Sensor Operation Mode (Temp2 SensorMode)*

The operating mode of the second temperature sensor connected to the terminals 3-4, which are defined as AN4 of the device, is determined by this parameter. Explanations for 3 different options are as follows.

**Off:** Should be in off mode when the second temperature sensor is not used.  
**Normal:** It is defined for use in a way to give warning and fault other than the defined values such as screw temperature sensor.

**Difference:** The value measured by the second temperature sensor is subtracted from the value measured by the first screw sensor, and error/warning conditions are created according to the difference value obtained.

#### *P190 Press Comp.Temp. (Press Comp.Temp.)*

If the value measured by the screw temperature sensor connected between terminal 7 and 8 is lower than the value specified with this parameter, instead of "P002 switch to idle pressure", the compressor switches to idle according to the new switch to idle pressure below.

Switch to Idle Pressure =  $P003 + (P002 - P003)/4$

#### *P191 Oil Freeze Prevention Temperature (Oil Freeze Prvnt)*

This function is used to prevent the screw oil from freezing in cold temperatures. If the compressor is going to remain off for a long period in cold temperatures (eg. over the weekend), it is possible to periodically heat up the screw oil. In this case, the compressor is switched on for a short period when the temperature measured by the Temperature-1 sensor reaches the value set in P191, To disable this function, set the value of P191 to -99.9°C

### 2.2.7 Mains Parameters

#### *P200 Mains Feed Unbalance Value % (Unbalance)*

The parameter used to control the unbalance between the phases.

#### *P201 Mains Feed Low-Voltage Fail (Volt Low Alarm)*

If one of the mains voltage phases connected to the terminals "25-24-23" of the device, which are defined as "R-S-T" is below the value specified with this parameter, the device indicates the relevant phase, switches to fault mode and stops the motor. Fault delay is 1 second.

#### *P202 Mains Feed Low-Voltage Warning (Volt Low Warn)*

If one of the mains voltage phases connected to the terminals "25-24-23" of the device, which are defined as "R-S-T" is below the value specified with this parameter, the device indicates the relevant phase and gives a warning. The warning delay is 1 second.

#### *P203 Mains Feed High-Voltage Fail (Volt High Alarm)*

If one of the mains voltage phases connected to the terminals "25-24-23" of the device, which are defined as "R-S-T" is above the value specified with this parameter, the device indicates the relevant phase, switches to fault mode and stops the motor. Fault delay is 1 second.

#### *P204 Mains Feed High-Voltage Warning (Volt High Warn)*

If one of the mains voltage phases connected to the terminals "25-24-23" of the device, which are defined as "R-S-T" is above the value specified with this parameter, the device indicates the relevant phase and gives a warning. The warning delay is 1 second.

#### *P205 Mains Feed Low-Frequency Fail (Freq Low Alarm)*

If the frequency of the mains voltage connected to the terminals "25-24-23" of the device, which are defined as "R-S-T" is below the value specified with this parameter, the device indicates a "Fre. Low Fault" message, goes into fault mode and stops the motor. Fault delay is 3 second.

#### *P206 Mains Feed Low-Frequency Warning (Freq Low Warn)*

If the frequency of the mains voltage connected to the terminals "25-24-23" of the device, which are defined as "R-S-T" is below the value specified with this parameter, the device indicates a "Fre. Low Warning" message. The warning delay is 2 second.

#### *P207 Mains Feed High-Frequency Fail (Freq High Alarm)*

If the frequency of the mains voltage connected to the terminals "25-24-23" of the device, which are defined as "R-S-T" is above the value specified with this parameter, the device indicates a "Fre. High Fault" message, goes into fault mode and stops the motor. Fault delay is 2 second.

#### *P208 Mains Feed High-Frequency Warning (Freq High Warn)*

If the frequency of the mains voltage connected to the terminals “25-24-23” of the device, which are defined as “R-S-T” is above the value specified with this parameter, the device indicates a “Fre. High Warning” message. The warning delay is 2 second.

#### *P209 Mains Input Wiring Type (Connection Type)*

There are three different types of connection:

##### **1P-Neutral:**

**3P-Neutral:** In this connection method, phase-neutral voltages are measured and Vr, Vs and Vt values are displayed on the Information Menu, Phase Voltages screen.

**3P:** In this connection method, phase-phase voltages are measured and Vrs, Vst and Vrt values are displayed on the Information Menu, Phase Voltages screen.

#### *P210 Mains Feed Phase Sequence protection (PhaseSeq Protect)*

With this parameter, the phase sequence control is activated or deactivated. For phase sequence control, the parameter "P153 Mains Failure Control" must also be activated.

#### *P211 Mains Feed Failure Control (Mains Faults)*

With this parameter, the mains voltage, frequency control and frequency sequence controls are activated or deactivated.

### 2.2.8 General Settings

#### *P220 Factory Password*

It is the parameter where the authorized password is set to access the factory level parameters. Factory value is 1923.

#### *P221 Service Password*

It is the parameter where the authorized password is set to access the service level parameters. Factory value is 1922.

#### *P222 User Password*

It is the parameter where the authorized password is set to access the user level parameters. Factory value is 1934.

#### *P224 Maximum Start Actions Per Hour (Maximum Startup)*

Determines the maximum number of times the compressor can be started within an hour.

#### *P225 Compressor Start Signal Input Type (Start Source)*

With this parameter, the source of run command for the panel is selected. The running options are through panel, remote with digital input and remote via communication. See "Application note Remote start"

#### *P226 Compressor Operation Mode (Working Mode)*

It is the parameter that determines the mode of operation of the panel. Automatic or Manual can be selected.

**Manuel mod** If the manual mode is selected, when the line pressure reaches the unloading pressure, the compressor is run unloaded, but the compressor continues to run continuously. It is not possible for the compressor to stop unless a malfunction occurs or a stop command is sent by the user.

**Otomatik mod** If the automatic mode is selected, if the line pressure is still above the on-load pressure after a certain period of time after the compressor is idle, the compressor is taken to the auto-standby mode and the compressor motor is stopped. Thus, energy savings are achieved.

When the compressor is in auto-standby mode, the compressor starts to work automatically when the line pressure reaches the on-load pressure. The parameters that affect the compressor starting are P003, P007, P023 and P229.

#### *P227 Boşta Çalışma Süresi S/D*

Dynamically changes the compressor's automatic standby time to save energy. This function can be used if P226 - Compressor Operating Mode is automatic After the compressor reaches the discharge pressure, it continues to run at idle for the time specified by the P026 parameter. When P227 - Idle Time S/D is activated, this time is tried to be reduced so as to save energy. If the time elapsed in auto-standby (Tauto) is greater than the time the compressor was idle (Tbos) before switching to auto-standby mode, that is, if the condition  $T_{auto} > T_{bos}$  is met, the auto-delay time assigned by the user with parameter P026 is gradually reduced. The reduction time is 30 seconds. However, this reduction is not reflected in the parameter. Therefore, if the device is de-energized for any reason, the reduced automatic standby delay value will be lost during operation.

#### *P228 Horn Operation Mode (Horn Mode)*

If horn function is assigned to one of the outputs, this parameter determines whether this horn output will be continuous or intermittent.

#### *P229 Pressure-Loss Prevention (PressLose Preve.)*

When the compressor line pressure reaches the switch to load pressure, it starts and it has to pass through some stages until it switches to load. When these stages take a certain period of time, the line pressure may decrease to undesired values until the compressor switches to load. This parameter is used to prevent these situations. Two different methods are defined: See "Application note Pressure loss prevention function"

**Method 1 Step:** An iteration-based step method. At the end of each switch to load operation, the supply pressure is checked and the pressure value of switching to the new load is updated in 0.1 bar steps. For example; if the switch to load pressure is 4bar, and when the compressor is on full load, the supply pressure is measured as 3.6 bar; the next switch to load pressure value is set as 4.1 bar, this way the compressor appoints 4.1 bar as the switch to load pressure value instead of P003.

**Method 2 Slope:** Considering the current pressure decrease rate and the times counted for the compressor to switch to load, the new switch to load pressure value is calculated.

#### *P230 Parameter Saving (Parameter Save)*

Used to save device parameters and recall saved parameters.

**No:** no actions

**Save:** Backs up the current state of the parameters.

**Use:** Restores the parameters that were saved with the backup command.

#### *P231 Language Selection (Language)*

Sets the language of the device. The device has Turkish and English languages in standard. When selected as user defined, the third language installed via USB is activated. See "Application note user defined third Language"

#### *P232 Factory Settings (Return Factory)*

There are 2 different restore factory settings options on the device. These are the built-in values in the device are the user-defined factory values that can be loaded via USB-MSC.

**No:** No: it does not perform any action.

**ENKO:** It loads the factory values to the device.

**U. Defined:** It loads the parameters loaded to the device via USB or with the Prolink Config program. See "Application Note Loading Defined Parameters Function".

*P233 Alarm History Reset (ClearFaultRecord)*

With this parameter, all fault logs in the device are deleted.

*P235 Motor Operation Time Reset (Motor Time Clear)*

The motor running and running on load times in the device are reset with this parameter.

*P236 Menu Timeout Duration (Menu Logout Time)*

If no button is pressed for the time specified by this parameter during the time the device stays in the menu, the system automatically exits from the menu. In addition, if no logout is made with “P171 Menu Logout” parameter after logging in for the menu, the menu can be accessed without password within the specified time.

*P237 Menu Logout*

Provides manual exit from the menu. Thus, it will be necessary to enter password on next menu login.

### 3. Hardware features, Terminal descriptions and connection suggestions

#### 3.1. Digital Inputs

The digital inputs must be connected as follows according to the factory settings of the CCS3200. The function at any input can be changed from the CCS3200's parameters. The connection must be adjusted according to the changed input function.

**Important Note: 15 Vdc voltage is generated from terminals 11 and 15 of the device, which are defined as +15V, to be used for the equipment produced by the device and to be connected to the inputs. No external voltage should be applied to these terminals. If applied, the device will malfunction and will be out of warranty.**

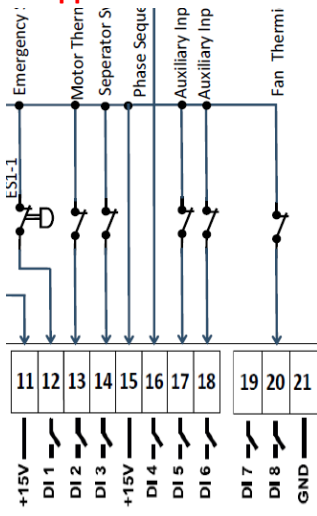

#### 3.2. Digital Outputs

CCS 3200 product has 6 relay outputs. The technical specifications of these outputs are as follows.

- Nominal Voltage : 250VAC
- Maximum Switching Voltage : 400VAC
- Nominal Current : 5A
- Maximum Current : 15A ( for 4 second, duty-factor %10)

#### 3.3. Analogue Inputs

#### 3.4. Communication

#### 4. Mechanic Properties.

Wight : 420 gr.  
 Dimensions : 154,6 x 133 x 59,5 mm  
 Panel Cut out : 151 x 115 mm

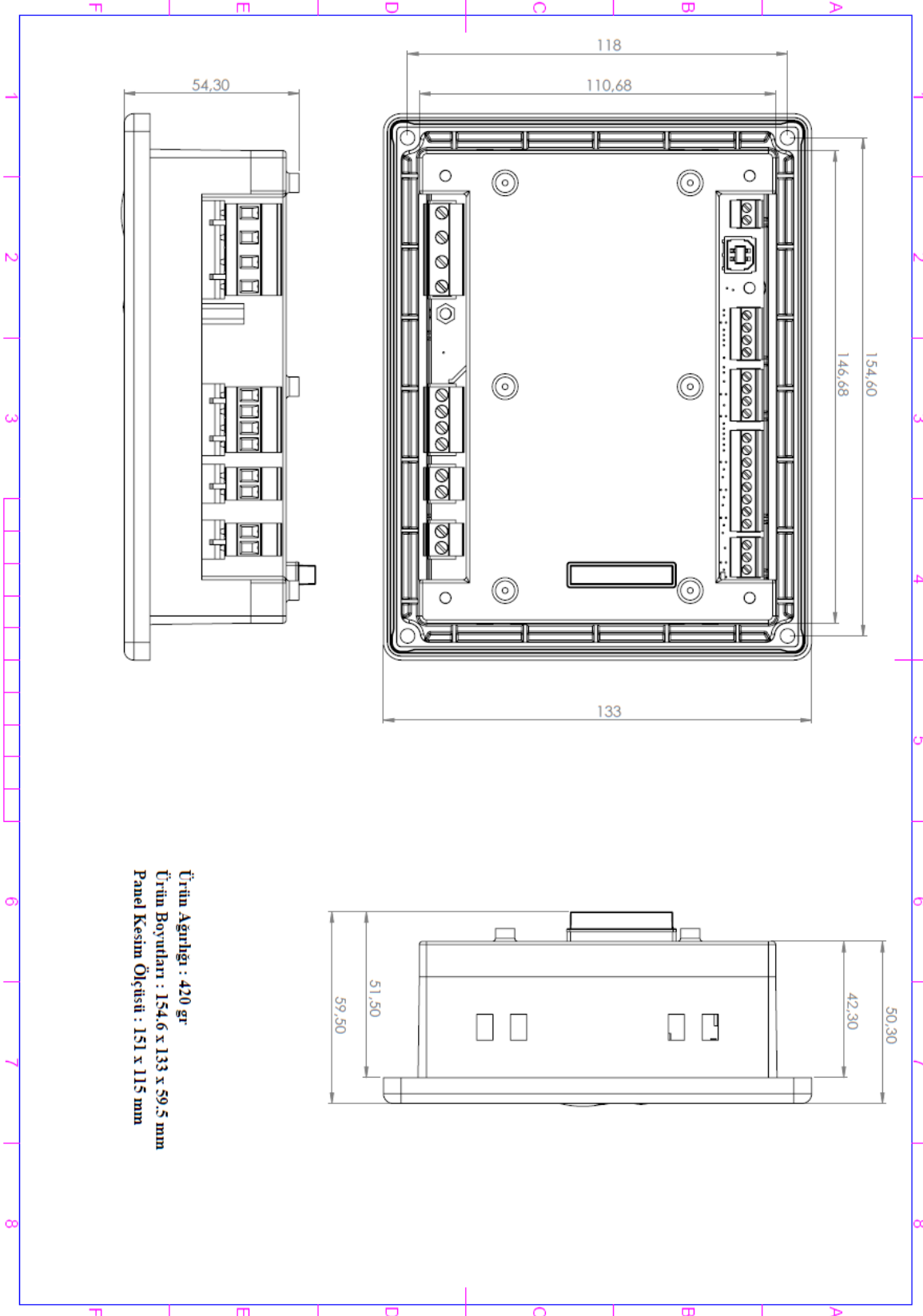



## With Extension Unit

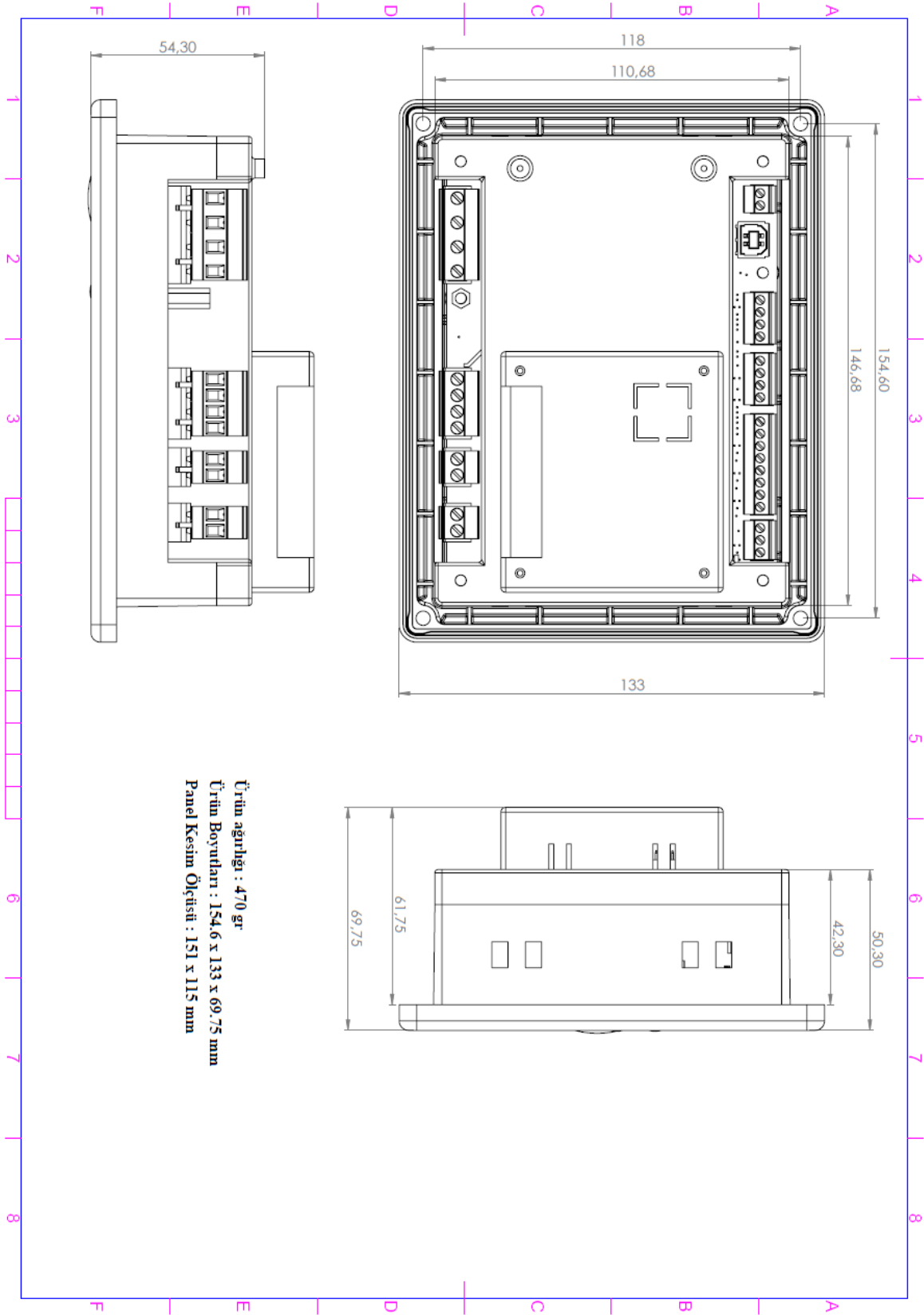

5. Connection Suggestions and points to take into consideration.

6. Warranty conditions:

7. Application Notes:

7.1. Application note Replacement and maintenance time reset.

There are 6 maintenance times in the CCS3200 device. To reset the maintenance times, enter the P149 Service Time Reset parameter under the service times parameters, The service time to be reset is selected with the up arrow key, To reset, press and hold the confirmation button for 3 seconds. At the end of the process, "No" is displayed on the screen. If it is desired to reset another maintenance time, the time to be reset is selected with the up arrow key and the same process is repeated.

Enter the Parameters menu by pressing the and keys at the same time ,

press the key until you see the screen, then press the key. screen appears

press the key until you see the screen, then press the key. Cursor blinks at None.

Press the button until you see the maintenance time you want to reset on the screen.

Press the key until you see no on the screen.

The maintenance time period you selected has been reset.

After your process is complete, you can see the Information Screen >> Service times >> reset service times.

7.2. Application note Alarm reset.

7.3. Application note Software update.

The software update can be performed via a Windows-based PC with a USB printer cable without the need for any software. If the version of the device you have is much older than the version you want to update, it is recommended to update the software with the "ENKO Prolink Config" program against the risk of returning the device parameters to their factory values.

**How to Update CCS3200 Software?**

The following steps are performed in order to update the software of the device.

1. The device is de-energized.
2. The stop button is pressed and the device is energized again.
3. If the RGB indicator on the device starts to flash alternately with a red-blue-green cycle, the stop button is released.

- If the USB cable is not connected between your computer and the device, the USB cable is connected.



The red indicator on the CCS3200 starts flashing.

- When you enter my computer via PC, a disk named CCS3200-B with a total area of 177kB is seen. If the total disk space is different from 177 kB, the steps in "Important Note 2" are followed. the file is deleted, then the updated software file is copied to this area.

**Important Note 1:** In case of any problem encountered during copying, you can prevent the problem by formatting the disk. The quick format option should be removed during formatting!

**Important Note 2: Free Memory Space 178 kB, 179 kB or 180kB problem!**

In cases where your free disk space appears to be different from 177kB, the steps to follow are as follows:

- After booting your device, if the free memory space is different from 177kB, first format your device.
- While in the My Computer directory, refresh the view by pressing the "F5" key in the relevant area or by right-clicking on any empty space and selecting "Refresh" from the pop-up window.
- If the free disk space is 178kB, 1, 179kB, 2, and 180kB, 3, text documents containing a few words should be created.
- Copy the files you created to the relevant disk space.
- Copy the software file you want to install to the relevant disk space.

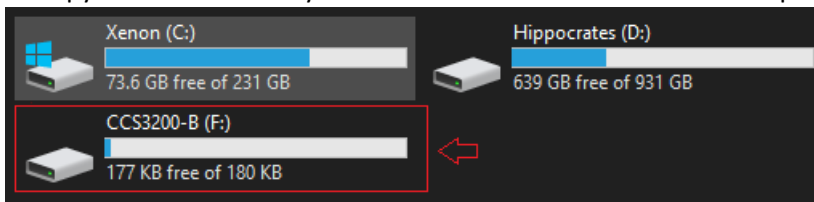

- After the copying process is completed, the device is de-energized and restarted, and the software-version value loaded is seen on the opening screen message.

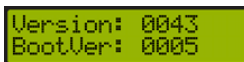

## 7.4 Application note Remote start.

## 7.5 Application note startup screen.

Changing the start-up screen is performed via a Windows-based PC with a USB printer cable, thanks to the "welcome.bin" file previously created with the "ENKO Prolink" program.

### How to Change the CCS3200 Start -Up Screen?

1. The "welcome.bin" file that was previously created with the "Enko Prolink" program is needed.
2. The CCS-3200, whose Start-up screen will be changed, is expected to be powered on (Stop button should not be pressed during startup. See "7.3 Application Note Software Update").
3. The connection is established by establishing a PC connection with a "USB Printer" cable, so that a computer connection is provided from the USB port of the CCS-3200.
4. "USB Drive" device is discovered under My Computer Folder on your Windows PC.
5. Copy the "welcome.bin" file created in step 1 to the disk space of the "USB Drive" device.
6. The device's USB cable connection is disconnected.
7. The device is ready to start with the Start-up screen defined by the User at the next startup.

## 7.6 Application note user defined third Language.

Adding a 3rd language (user-defined) to the CCS3200 is done via a Windows-based PC with a USB printer cable, thanks to the "language.bin" file created with the "ENKO Prolink" program.

### How to Install CCS3200 User Defined Language?

1. The "language.bin" file that was previously created with the "Enko Prolink" program is needed.
2. CCS-3200, which will be loaded with User Defined language, is expected to be powered on (Stop button should not be pressed during startup. See "7.3 Application Note Software Update").
3. The connection is established by establishing a PC connection with a "USB Printer" cable, so that a computer connection is provided from the USB port of the CCS-3200.
4. "USB Drive" device is discovered under My Computer Folder on your Windows PC.
5. The "language.bin" file created in step 1 is copied to the disk space of the "USB Drive" device.
6. The device's USB cable connection is disconnected.
7. The device is configured by changing the P.232 Language Option parameter from the device parameters to "User Defined (2)".

## 7.7 Application note Preheating.

## 7.8 Application note Oil freezing prevention.

## 7.9 Application note Running with pressure switch.

## 7.10 Application note Temperature dependent fan control function.

**Note:** The value measured by the screw temperature sensor connected to terminals 7-8, defined as AN2, will be indicated as Screw Temperature in the application description below.

When the function of one of the Digital Outputs is assigned as Fan; (Fan Function is assigned to output 32-33 which is defined as Out1 in device default values).

If "Screw Temperature  $\geq$  P129 Fan Operating Temperature", the output becomes active and the fan operates. In this process;

- FAN output remains passive until the load is switched on during the motor starting process.
  - Fan output is cut off when any malfunction occurs in the system.
  - Even if there is "Screw Temperature > P129 Fan Operating Temperature" after the compressor stops, the Fan output remains active for the time determined by the "P36 Fan Maximum Operating Time" parameter. During this period, if the screw temperature measured by the 1st temperature sensor falls below the value entered in the "P129 Fan Operating Temperature" parameter, the fan output becomes passive.
- If "Screw Temperature <= P130 Fan Stop Temperature", the output becomes passive and the Fan stops.

### 7.11 Application note Dryer Functions,

Two types of dryer functions are available in the CCS 3200. When the functions are assigned to one of the CCS3200's outputs, it works as follows.

**Dryer-Z:** This is an output for the dryer, which is activated when the compressor starts working (pre-heat, off-load and on-load). When the compressor stops working, this output will continue to remain active for the duration set in P037, before being deactivated.

**Dryer-S:** This is an output for the dryer, which is activated based on the temperature measured by the Temperature-2 sensor and the range defined in P181 and P182. When the compressor is working (pre-heat, off-load and on-load), this output will be activated when the temperature measured by the Temperature-2 sensor goes above the value set in P181, and deactivated when it reaches the value set in P182.

When the compressor transitions to the auto-wait, air-discharge or wait states, if the temperature has reached the value set in P182, this output is deactivated; if not, the dryer output will remain active for the duration set in P037 after the compressor has stopped.

### 7.12 Application note Pressure loss prevention function

### 7.13 Application note Idle run time optimization function

### 7.14 Application note Pressure Compensation Temperature function

### 7.15 Application note Mains connection type.

For phase sequence control, when the mains voltages are connected to the device, the value of the P56 Input Function4 parameter from the input parameters must be set to "None".

### 7.16 Application note Running Method.

### 7.17 Application note Dynamic Idle Run Function.

### 7.18 Application note Loading Defined Parameters Function.

Uploading of user-defined parameters is performed via a Windows-based PC with a USB printer cable, thanks to the "userpars.bin" file previously created with the "ENKO Prolink" program.

#### How to Load CCS3200 User Defined Parameter List?

1. 1. The "userpars.bin" file that was previously created with the "Enko Prolink" program is needed.
2. 2. CCS-3200, which will be loaded with User Defined language, is expected to be powered on (Stop button should not be pressed during startup. See "7.3 Application Note Software Update").
3. 3. The connection is established by establishing a PC connection with a "USB Printer" cable, so that a computer connection is provided from the USB port of the CCS-3200.
4. 4. "USB Drive" device is discovered under My Computer Folder on your Windows PC.
5. 5. The "userpars.bin" file created in step 1 is copied to the disk space of the "USB Drive" device.

6. 6. The device's USB cable connection is disconnected.
7. 7. The device is configured by changing the P.233 Restore Factory Settings parameter to “User Defined (2)” from the device parameters.

#### [7.19 Application note Automatic Power On Function in Power Failure.](#)

If CCS3200 is in automatic operation mode and running the compressor; When the value of the P27 Power failure delay parameter, one of the timing parameters, is different from “0”, it waits for the entered value in seconds and starts the compressor again. In order to disable the automatic start function in case of power failure, set P27 Power failure delay parameter to “0”.

#### [7.20 Application note Inverter Application with Simple Method](#)

## 8. Version Descriptions

### 8.1. Software Version

### 8.2. Document Version

# 9. Wiring Diagram

## CCS 3200 BASIC CONNECTION DIAGRAM

