



DEEP SEA ELECTRONICS

DSE327 Operator Manual

Document Number: 057-286

Author: Matt Simpson





Deep Sea Electronics Ltd
Highfield House
Hunmanby
North Yorkshire
YO14 0PH
ENGLAND

Sales Tel: +44 (0) 1723 890099

E-mail: sales@deepseaelectronics.com
Website: www.deepseaelectronics.com

DSE327 Operator Manual

© Deep Sea Electronics Ltd

All rights reserved. No part of this publication may be reproduced in any material form (including photocopying or storing in any medium by electronic means or other) without the written permission of the copyright holder except in accordance with the provisions of the Copyright, Designs and Patents Act 1988.

Applications for the copyright holder's written permission to reproduce any part of this publication must be addressed to Deep Sea Electronics Ltd at the address above.

The DSE logo and the names DSEgenset[®], DSEats[®], DSEcontrol[®] and DSEpower[®] are UK registered trademarks of Deep Sea Electronics Ltd.

Any reference to trademarked product names used within this publication is owned by their respective companies.

Deep Sea Electronics Ltd reserves the right to change the contents of this document without prior notice.

Amendments Since Last Publication

Amd. No.	Comments
1	Initial Release
2	Added Section <i>Configuration Mode</i>
3	Updated to include <i>Product Variants</i> section.
4	Minor update. Configuration mode description amended.

TABLE OF CONTENTS

Section	Page
1 INTRODUCTION.....	4
1.1 CLARIFICATION OF NOTATION.....	5
1.2 GLOSSARY OF TERMS	5
1.3 BIBLIOGRAPHY	5
1.3.1 INSTALLATION INSTRUCTIONS	5
1.3.2 TRAINING DOCUMENTS.....	5
1.3.3 THIRD PARTY DOCUMENTS	5
2 SPECIFICATIONS	6
2.1 PRODUCT VARIANTS.....	6
2.2 TEMPERATURE SPECIFICATION	6
2.3 TERMINAL SPECIFICATION.....	6
2.4 POWER SUPPLY REQUIREMENTS.....	7
2.4.1 230 V VARIANT.....	7
2.4.2 110 V VARIANT.....	7
2.5 VOLTAGE AND FREQUENCY SENSING	8
2.5.1 230 V VARIANT.....	8
2.5.2 110 V VARIANT.....	8
2.6 OUTPUTS.....	8
2.6.1 S1 AND S2 CLOSE RELAY.....	8
2.6.2 RUN RELAY.....	8
2.7 DIMENSIONS AND MOUNTING	9
2.7.1 WEIGHT.....	9
2.8 APPLICABLE STANDARDS.....	10
3 INSTALLATION	11
3.1 USER CONNECTIONS	11
3.2 CONNECTION DESCRIPTIONS	12
3.3 TYPICAL WIRING DIAGRAM	13
3.3.1 SINGLE PHASE, 2 WIRE (L1 & N).....	13
3.3.2 3 PHASE, 4 WIRE (L1, L2, L3 & N).....	14
4 OPERATION.....	15
4.1 LED INDICATORS	16
4.1.1 S1 / S2 AVAILABLE LED.....	16
4.1.2 S1 / S2 BREAKER LED.....	16
4.2 TIMERS.....	17
4.3 TIMING DIAGRAM	18
4.3.1 S1 FAILURE.....	18
4.3.1.1 ABOVE POWER SUPPLY LIMIT	18
4.3.1.2 BELOW POWER SUPPLY LIMIT.....	18
4.3.2 S1 RETURN.....	19
5 PROTECTIONS	20
6 CONFIGURATION MODE	21
6.1 ENTERING CONFIGURATION MODE.....	21
6.2 SELECTING THE CONFIGURATION.....	22
6.3 SAVING THE CONFIGURATION	22
7 MAINTENANCE, SPARES, REPAIR AND SERVICING	23
8 WARRANTY	23
9 DISPOSAL.....	23
9.1 WEEE (WASTE ELECTRICAL AND ELECTRONIC EQUIPMENT).....	23

1 INTRODUCTION

This document details the installation and operational requirements of the DSE327 module, part of the DSEATS ® range of products.

The manual forms part of the product and should be kept for the entire life of the product. If the product is passed or supplied to another party, ensure that this document is passed to them for reference purposes.

This is not a *controlled document*. You will not be automatically informed of updates. Any future updates of this document will be included on the DSE website at www.deepseaelectronics.com.

The DSE327 is housed within robust plastic case designed for DIN rail mounting. Connections to the module are via screw terminals.



The module has been designed to automatically transfer the load from one supply to another, typically the mains supply (S1) and a standby generator (S2), or alternatively two mains supplies where S1 is always the priority.

It monitors the two supply voltages, indicating the supply status and breaker conditions via the fascia LEDs. The module automatically transfers the load to S2 in case of an S1 supply failure.

The module's fascia allows adjustment of the *Breaker Delay* timers. For more information see the section entitled *Timers* elsewhere in this manual.

1.1 CLARIFICATION OF NOTATION

Clarification of notation used within this publication.

	NOTE:	Highlights an essential element of a procedure to ensure correctness.
	CAUTION!	Indicates a procedure or practice, which, if not strictly observed, could result in damage or destruction of equipment.
	WARNING!	Indicates a procedure or practice, which could result in injury to personnel or loss of life if not followed correctly.

1.2 GLOSSARY OF TERMS

Term	Description
DSE3XX	All modules in the DSE3xx.
ATS	Automatic Transfer Switch
S1	Supply 1, normally connected to the mains supply
S2	Supply 2, normally connected to the generator supply

1.3 BIBLIOGRAPHY

This document refers to and is referred to by the following DSE publications which can be obtained from the DSE website www.deepseaelectronics.com.

1.3.1 INSTALLATION INSTRUCTIONS

DSE Part	Description
053-237	DSE327 Installation Instructions

1.3.2 TRAINING DOCUMENTS

DSE Part	Description
056-022	Switchgear Control
056-091	Equipotential Earth Bonding

1.3.3 THIRD PARTY DOCUMENTS

The following third party documents are also referred to:

ISBN	Description
1-55937-879-4	IEEE Std C37.2-1996 IEEE Standard Electrical Power System Device Function Numbers and Contact Designations. Published by Institute of Electrical and Electronics Engineers Inc

2 SPECIFICATIONS

2.1 PRODUCT VARIANTS

⚠ CAUTION! Always ensure that the DSE327 ATS is the correct variant for the application. For more information on *Product Variants* please contact DSE Technical Support; support@deepseaelectronics.com

The DSE327 is supplied with varying hardware and configuration parameters depending on the application requirements. The product hardware and configuration variant are referenced within the *Product Part Number* found on the rear of the module as shown below;

Product Part Number

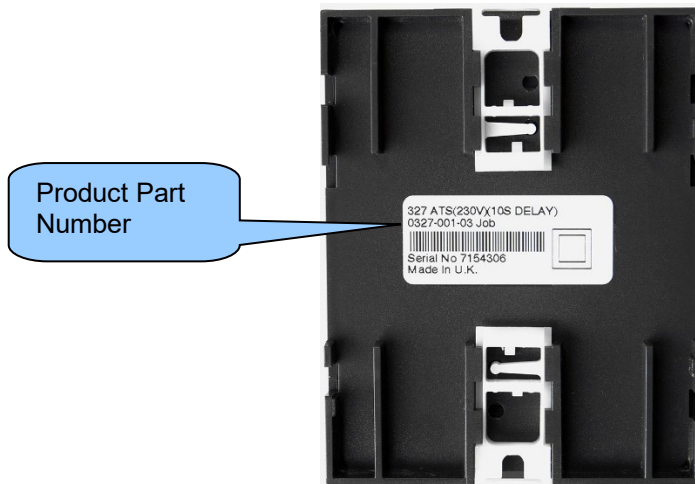

2.2 TEMPERATURE SPECIFICATION

Status	Specification
Operating	-30 °C to 70 °C (-22 °F to 158 °F)
Storage	-40 °C to 80 °C (-40 °F to 176 °F)

2.3 TERMINAL SPECIFICATION

Description	Specification	 <p>Example showing cable entry</p>
Connection Type	Screw terminal, rising clamp, no internal spring	
Minimum Cable Size	0.5 mm ² (AWG 20)	
Maximum Cable Size	2.5 mm ² (AWG 13)	
Tightening Torque	0.5 Nm (4.5 lb-in)	
Wire Strip Length	7 mm (9/32")	

2.4 POWER SUPPLY REQUIREMENTS

NOTE: As the power supply is between L1 and N, topologies without a neutral connection are not supported.

2.4.1 230 V VARIANT

Description	Specification
Power Supply Terminals	L1 and N from S1 / S2 supplies
Nominal Frequency	50 Hz
Nominal Voltage	230 V
Minimum S1 Power Supply Voltage	50 V to activate S1 LEDs 184 V to close the <i>Close S1</i> output
Minimum S2 Power Supply Voltage	70 V to activate S2 LEDs 184 V to close the <i>Close S2</i> output
Maximum Power Supply Voltage	300 V
Maximum Operating Power Auto mode with all LEDs illuminated	1 W (S1), 0.7 W (S2)
Maximum Standby Power	1 W (S1), 0.7 W (S2)
Frequency Range	40 Hz to 60 Hz

2.4.2 110 V VARIANT

Description	Specification
Power Supply Terminals	L1 and N from S1 / S2 supplies
Nominal Frequency	60 Hz
Nominal Voltage	110 V
Minimum S1 Power Supply Voltage	25 V to activate S1 LEDs 88 V to close the <i>Close S1</i> output
Minimum S2 Power Supply Voltage	30 V to activate S2 LEDs 88 V to close the <i>Close S2</i> output
Maximum Power Supply Voltage	150 V
Maximum Operating Power Auto mode with all LEDs illuminated	1 W (S1), 0.7 W (S2)
Maximum Standby Power	1 W (S1), 0.7 W (S2)
Frequency Range	50 Hz to 70 Hz

2.5 VOLTAGE AND FREQUENCY SENSING

NOTE: Frequency failure detection is not supported within this module. However, the module only supports AC supplies in the range of 40 Hz to 70 Hz.

NOTE: Voltage phase to phase failure detection is not supported within this module. However, the module supports a maximum phase to phase AC supply of 520 V.

2.5.1 230 V VARIANT

Description	Specification
Measurement Type	True RMS conversion
Sample Rate	1 Hz
Harmonics	Up to the 10 th
Phase To Neutral	180 V to 300 V
Phase To Phase	520 V Maximum
Resolution	1 V phase to neutral
Accuracy	±5% of full scale phase to neutral
Minimum Frequency	40 Hz
Maximum Frequency	60 Hz

2.5.2 110 V VARIANT

Description	Specification
Measurement Type	True RMS conversion
Sample Rate	1 Hz
Harmonics	Up to the 10 th
Phase To Neutral	85 V to 150 V
Phase To Phase	520 V Maximum
Resolution	1 V phase to neutral
Accuracy	±5% of full scale phase to neutral
Minimum Frequency	50 Hz
Maximum Frequency	70 Hz

2.6 OUTPUTS

2.6.1 S1 AND S2 CLOSE RELAY

Description	Specification
Type	Normally Open Volt-Free Relay.
Rating	8 A at 250 Vac 5 A at 30 Vdc

2.6.2 RUN RELAY

Description	Specification
Type	Normally Closed Volt-Free Relay.
Rating	8 A at 250 Vac 5 A at 30 Vdc

2.7 DIMENSIONS AND MOUNTING

NOTE: In conditions of excessive vibration, mount the panel on suitable anti-vibration mounting

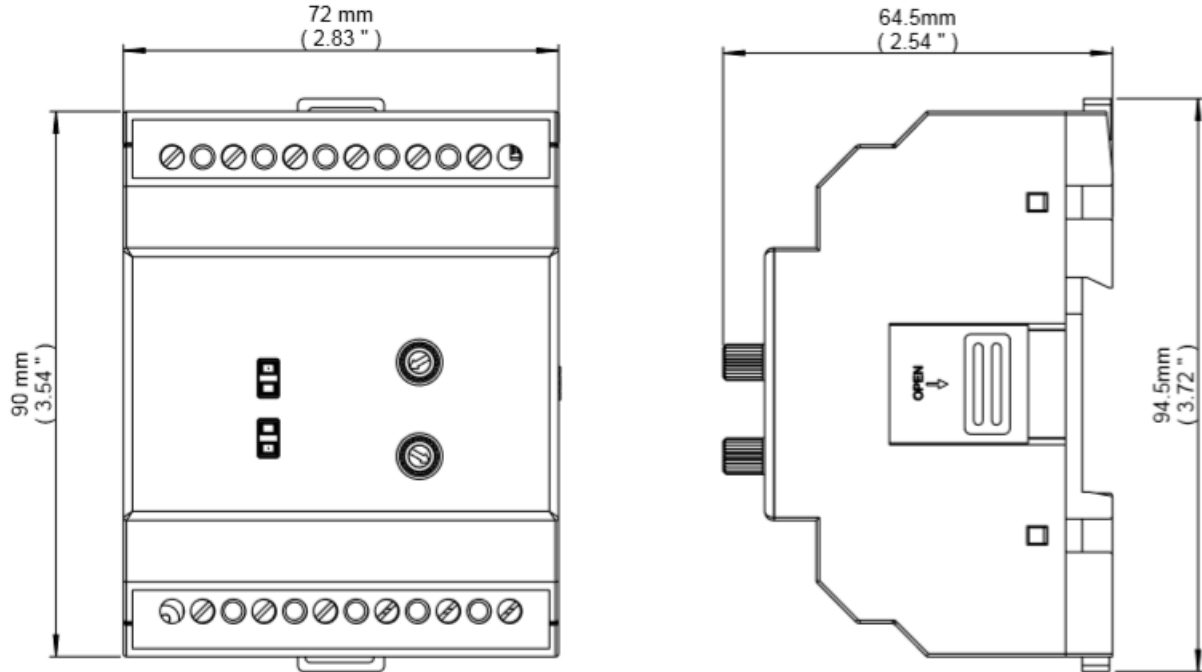

Description	Specification
Mounting Type	DIN rail or chassis mounting
DIN Rail Width	EN 50022: 35 mm (1.4 ")
Dimensions Mounted on DIN Rail	72 mm X 94.5 mm X 64.5 mm (2.83 " X 3.72 " X 2.54 ")
Dimensions Using Mounting Holes	72 mm X 112 mm X 64.5 mm (2.83 " X 4.41 " X 2.54 ")
Chassis Mounting Holes	M4 (0.25 ")
Chassis Mounting Hole Centres	100.5 mm (3.96 ") at the module centre line

2.7.1 WEIGHT

Description	Specification
Module Weight	0.20 kg (230 V variant) 0.22 kg (110 V variant)
Shipped Weight	Includes all packaging and installation instructions 0.16 kg (230 V variant) 0.18 kg (110 V variant)

2.8 APPLICABLE STANDARDS

Standard	Description
BS 4884-1	This document conforms to BS4884-1 1992 Specification for presentation of essential information.
BS 4884-2	This document conforms to BS4884-2 1993 Guide to content
BS 4884-3	This document conforms to BS4884-3 1993 Guide to presentation
BS EN 60068-2-1 (Minimum temperature)	-30 °C (-22 °F)
BS EN 60068-2-2 (Maximum temperature)	+70 °C (158 °F)
BS EN 60950	Safety of information technology equipment, including electrical business equipment
BS EN 60068-2-30 (Damp heat cyclic)	20°C to 55 °C at 95% relative humidity for 48 hours
BS EN 60068-2-78 (Damp heat static)	40 °C at 95% relative humidity for 48 hours
BS EN 60950 (Electrical safety)	Safety of information technology equipment, including electrical business equipment
BS EN 61000-6-2 (Electro-magnetic Compatibility)	EMC Generic Immunity Standard (Industrial)
BS EN 61000-6-4 (Electro-magnetic Compatibility)	EMC Generic Emission Standard (Industrial)
BS EN 61000-6-2	EMC Generic Immunity Standard (Industrial)
BS EN 61000-6-4	EMC Generic Emission Standard (Industrial)
BS EN 60529 (Degrees of protection provided by enclosures)	IP20
UL508 NEMA rating (Approximate)	1
IEEE C37.2 (Standard Electrical Power System Device Function Numbers and Contact Designations)	<p>Under the scope of IEEE 37.2, function numbers can also be used to represent functions in microprocessor devices and software programs. The controller is device number 11L-8000 (Multifunction device protecting Line (generator) –module).</p> <p>As the module is configurable by the generator OEM, the functions covered by the module vary. Depending on module configuration, the device numbers included within the module could be:</p> <ul style="list-style-type: none"> 2 – Time-delay Starting or Closing Relay 3 – Checking or Interlocking Relay 6 – Starting Circuit Breaker 10 – Unit Sequence Switch 11 – Multifunction Device 27 – AC Under Voltage Relay 29 – Isolating Contactor 59 – AC Overvoltage Relay

In line with our policy of continual development, Deep Sea Electronics Ltd, reserve the right to change specification without notice.

3 INSTALLATION

3.1 USER CONNECTIONS

To aid user connection, terminal descriptions are applied on the front of the module to help identify terminal functions. An example of this is shown below.

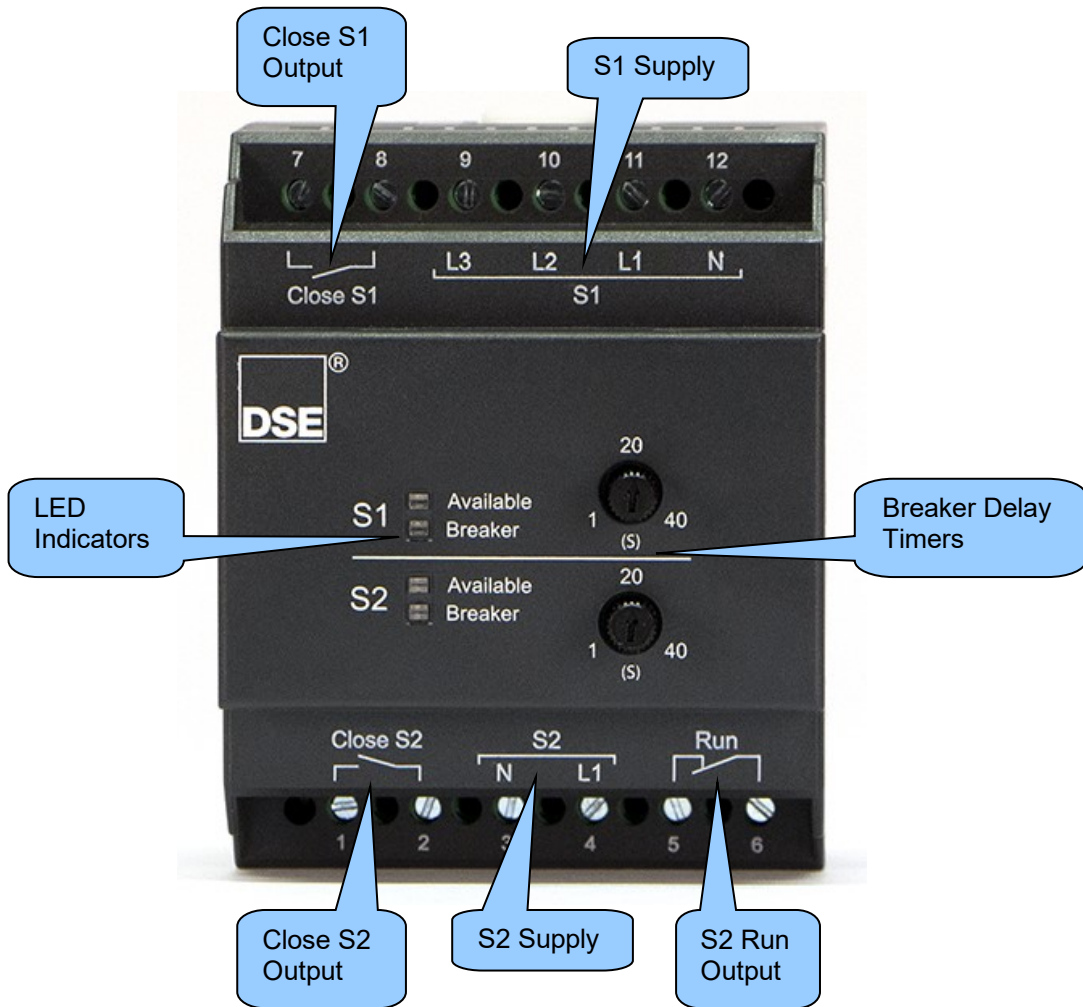

3.2 CONNECTION DESCRIPTIONS

Name	PIN No	Description	Cable Size	Notes
Close S2	1	Normally Open Volt-Free Relay	1.0 mm ² AWG 18	Used to control the S2 breaker coil.
	2			
S2	3	S2 Neutral Voltage monitoring	1.0 mm ² AWG 18	Connect to S2 N. (Recommend 2 A fuse) Power supply for module in event of S1 failure.
	4	S2 L1 Voltage monitoring	1.0 mm ² AWG 18	Connect to S2 L1. (Recommend 2 A fuse) Power supply for module in event of S1 failure.
Run	5	Normally Closed Volt-Free Relay	1.0 mm ² AWG 18	Used to issue a Start command to S2 (generator) Upon S1 (mains) failure the contact becomes closed.
	6			
Close S1	7	Normally Open Volt-Free Relay	1.0 mm ² AWG 18	Used to control the S1 breaker coil.
	8			
S1	9	S1 L3 Voltage monitoring	1.0 mm ² AWG 18	Connect to S1 L3. (Recommend 2 A fuse)
	10	S1 L2 Voltage monitoring	1.0 mm ² AWG 18	Connect to S1 L2. (Recommend 2 A fuse)
	11	S1 L1 Voltage monitoring	1.0 mm ² AWG 18	Connect to S1 L1. (Recommend 2 A fuse) Power supply for module.
	12	S1 Neutral Voltage monitoring	1.0 mm ² AWG 18	Connect to S1 N. (Recommend 2 A fuse) Power supply for module.

3.3 TYPICAL WIRING DIAGRAM

As every system has different requirements, these diagrams show only a TYPICAL system and do not intend to show a complete system.

Manufacturers and panel builders may use these diagrams as a starting point, however you are referred to the completed system diagram provided by your system manufacturer for complete wiring detail.

Further wiring suggestions are available in the following DSE publications, available at www.deepseaelectronics.com.

DSE Part	Description
056-022	Switchgear Control
056-091	Equipotential Earth Bonding

3.3.1 SINGLE PHASE, 2 WIRE (L1 & N)

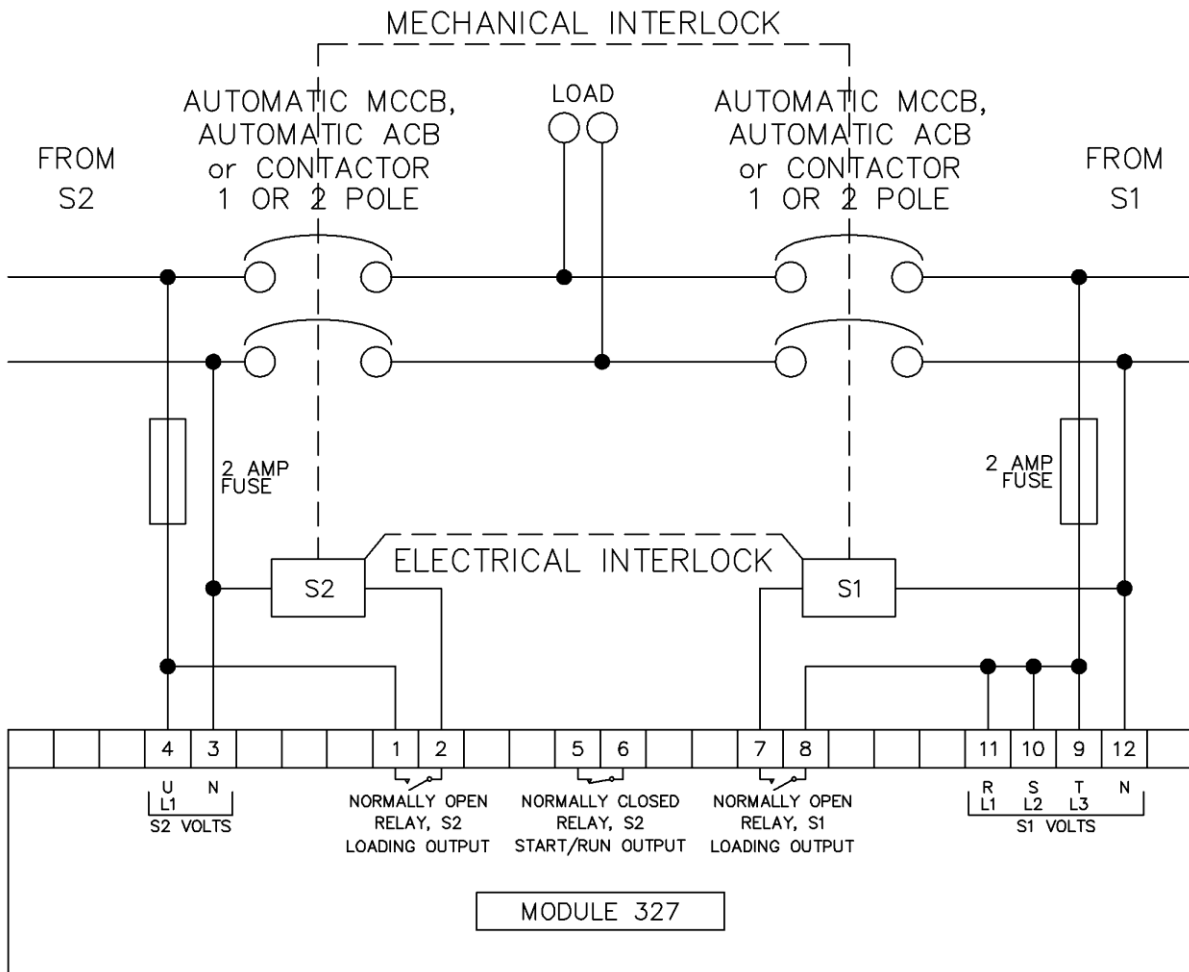

3.3.2 3 PHASE, 4 WIRE (L1, L2, L3 & N)

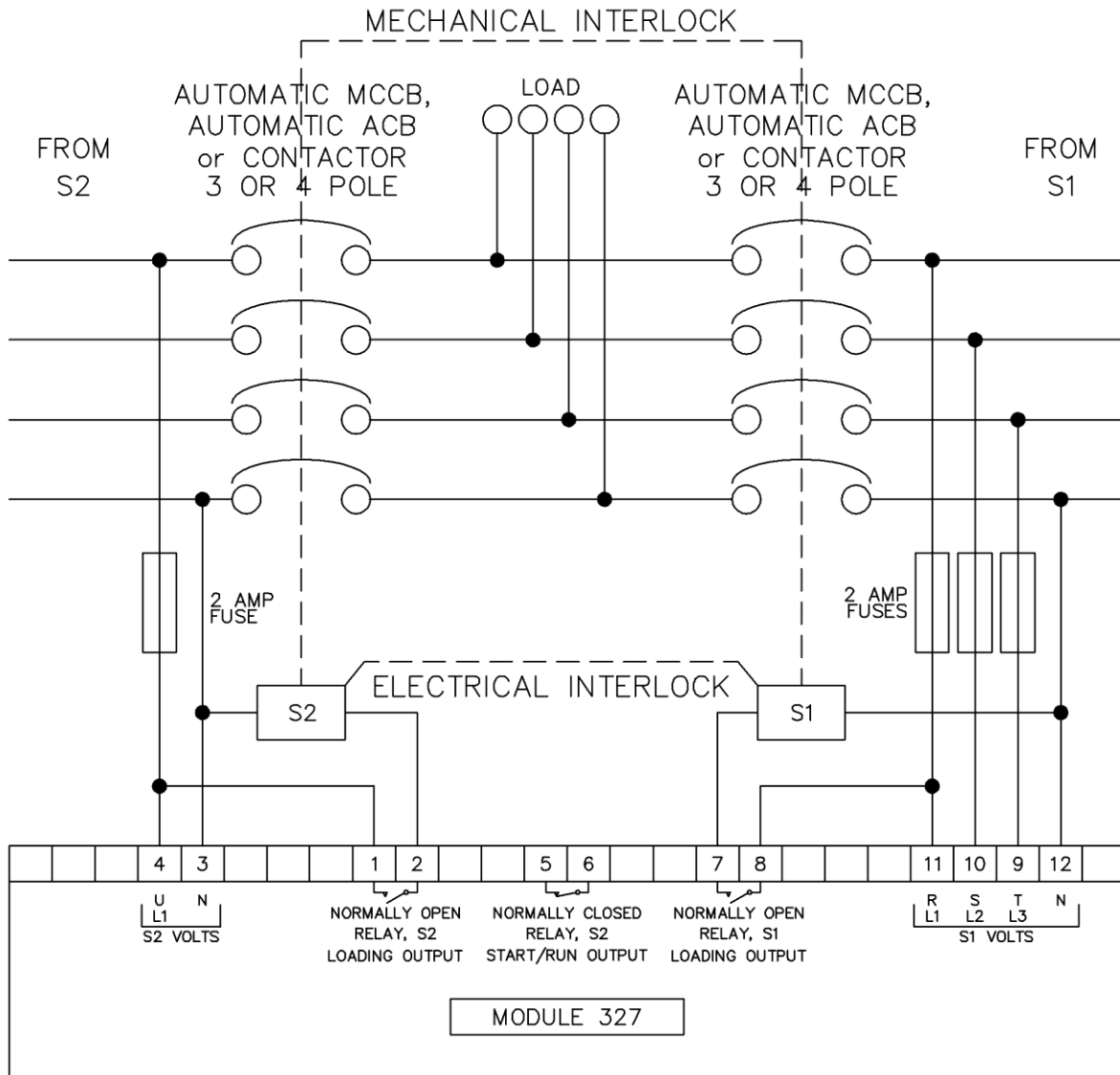

4 OPERATION

The DSE327 only offers protection for phase to neutral voltage failure and has one mode of automatic operation with two user configurable *Breaker Delays* for S1 and S2.

If the S1 supply is out of limits on any of the phases, the *S1 Available* LED flashes twice every second for the *S1 Transient Delay* (5 seconds). Upon the *S1 Transient Delay* ending, if the S1 supply voltage is above the minimum supply voltage (25 V to 50 V), the *S1 Available* LED flashes once every 4 seconds for the duration of the failure. At the same time, the *Run* output closes to start/run the S2 supply. During this time the *Close S1* output remains closed.

However, if the S1 supply voltage is below the minimum supply voltage (25 V to 50 V), the *S1 Close* output opens immediately, and all S1 LEDs extinguish. The *Run* output also activates at this time to start/run S2.

Upon sensing S2 within limits, the *S2 Available* LED flashes every second for the duration of the *S2 Breaker Delay*. Upon the *S2 Breaker Delay* ending, the LED remains lit and the *Close S1* output opens. After the *Transfer Delay* (1 second), the *Close S2* output closes.

If the S2 supply goes out of limits on the sensed phase, the *S2 Available* LED flashes twice every second for the *S2 Transient Delay* (5 seconds). Upon the *S2 Transient Delay* ending if the S1 supply voltage is above the minimum supply voltage (30 V to 70 V), the *S2 Available* LED flashes once every 4 seconds for the duration of the failure. At the same time, the *Run* output remains closed to restart/run the S2 supply. During this time the *Close S2* output remains closed.

However, if the S2 supply voltage is below the minimum supply voltage (30 V to 70 V), the *S2 Close* output opens immediately, and all S2 LEDs extinguish. The *Run* output remains active at this time to restart/run S2.

Upon sensing S1 within limits, the *S1 Available* LED flashes every second for the duration of the *S1 Breaker Delay*. Upon the *S1 Breaker Delay* ending, the LED remains lit and the *Close S2* output opens. After the *Transfer Delay* (1 second), the *Close S1* output closes and the *S2 Cooling* time (6 seconds) begins. Once the *S2 Cooling* time has completed, the *Run* output opens to stop S2.

4.1 LED INDICATORS

4.1.1 S1 / S2 AVAILABLE LED

Two *Available LEDs* are shown on the module panel. The LEDs indicate if the AC supply is *Available*. For further information on *Protection* values refer to section entitled *Protection* section elsewhere in this manual.

S1 / S2 Available LED	Description
Blink Twice per second •• •• •• •• •• (2 Hz)	Supply Failing, <i>Transient Delay</i> in progress Under Voltage: ~25% of Nominal < Supply < 80% of Nominal Over Voltage: 120% of Nominal < Supply
Blink Once every four seconds • •••• (0.25 Hz)	Supply Failed Under Voltage: ~25% of Nominal < Supply < 80% of Nominal Over Voltage: 120% of Nominal < Supply
Blink Once every second • • • • • (1 Hz)	Breaker Delay in progress
Lit	Supply Available 90% of Nominal < Supply < 110% of Nominal
Unlit	Supply Unavailable Supply < ~25% of Nominal

4.1.2 S1 / S2 BREAKER LED

Two *Breaker LEDs* are shown on the module panel. The LEDs indicate the *Breaker* status for each supply.

S1 / S2 Breaker LED	Description
Lit	Breaker Close Request
Unlit	Breaker Open Request

4.2 TIMERS

Timer	Time Range
S1 Breaker Delay	1 s to 40 s $\pm 3\%$
S2 Breaker Delay	1 s to 40 s $\pm 3\%$
S1 Transient Delay	5 s $\pm 3\%$
S2 Transient Delay	4 s $\pm 3\%$
Transfer Delay	<div style="border: 1px solid black; padding: 5px;">  NOTE: For Product Part Number 0327-001-03 the Transfer Delay Timer is fixed at 10 seconds. For all other hardware variants, the timer is fixed to 1 second. </div>
	1 s $\pm 3\%$
S2 Cooling	6 s $\pm 3\%$

S1 / S2 Breaker Delay

The *S1 / S2 Breaker Delay* defines the length of time between S1 / S2 becoming *Available* and the *Close S1 / S2* output closing. This timer is used to ensure the S1 / S2 supply is stable and has reached its nominal before placing S1 / S2 on load.

S1 / S2 Transient Delay

The *S1 / S2 Transient Delay* defines the length of time between the supply failing and a S1 / S2 Failure becoming active. This allows for fluctuations in load which may cause the supply to temporarily fall below their protection values.

Transfer Delay

The *Transfer Delay* defines the length of time for an S1 / S2 transfer to take place. During this time both *Close S1* and *Close S2* outputs remain open.

S2 Cooling

The *S2 Cooling* defines the length of time that the *Run* output remains closed after a transfer from S2 to S1. This timer is used to allow the generator (S2) to cooldown after being on load.

4.3 TIMING DIAGRAM

The following *Timing Diagrams* detail the sequence of events during a typical S1 to S2 transfer in various scenarios. In all scenarios, the *S1 / S2 Breaker Delays* have been configured to 5 seconds.

4.3.1 S1 FAILURE

4.3.1.1 ABOVE POWER SUPPLY LIMIT

In this example, the S1 supply voltage has risen above the *S1 Breaker Over Voltage Trip* or fallen below the *S1 Breaker Under Voltage Trip* whilst remaining above the range of the module's power supply.

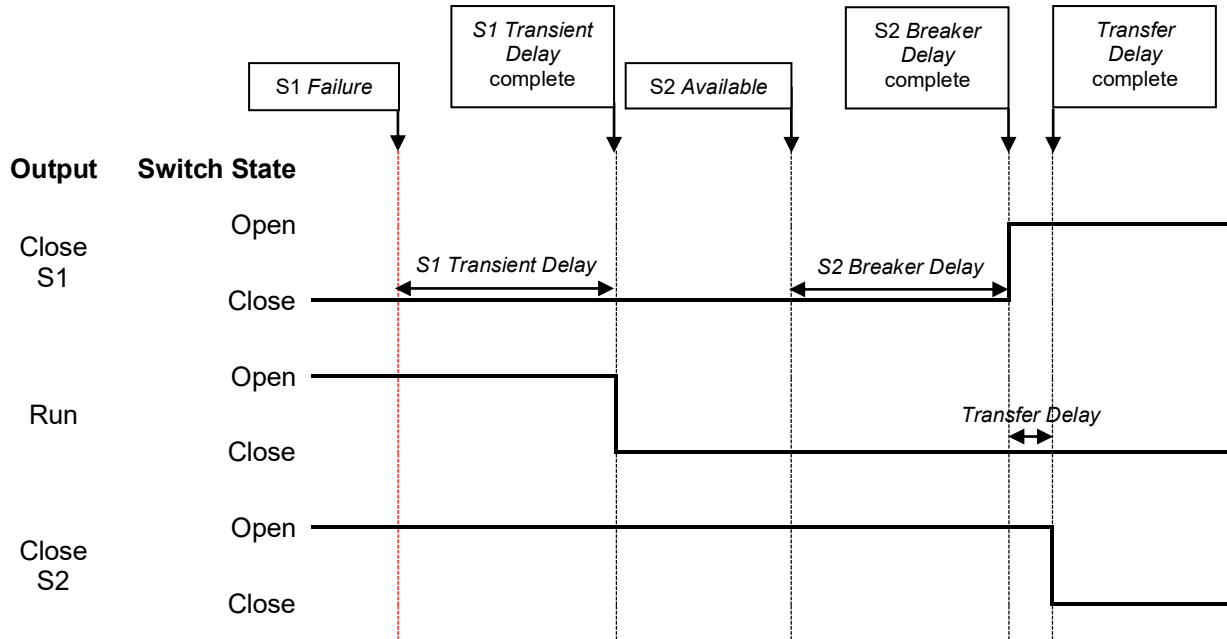

4.3.1.2 BELOW POWER SUPPLY LIMIT

In this example, the S1 supply voltage has or fallen below the *S1 Breaker Under Voltage Trip* and below the range of the module's power supply.

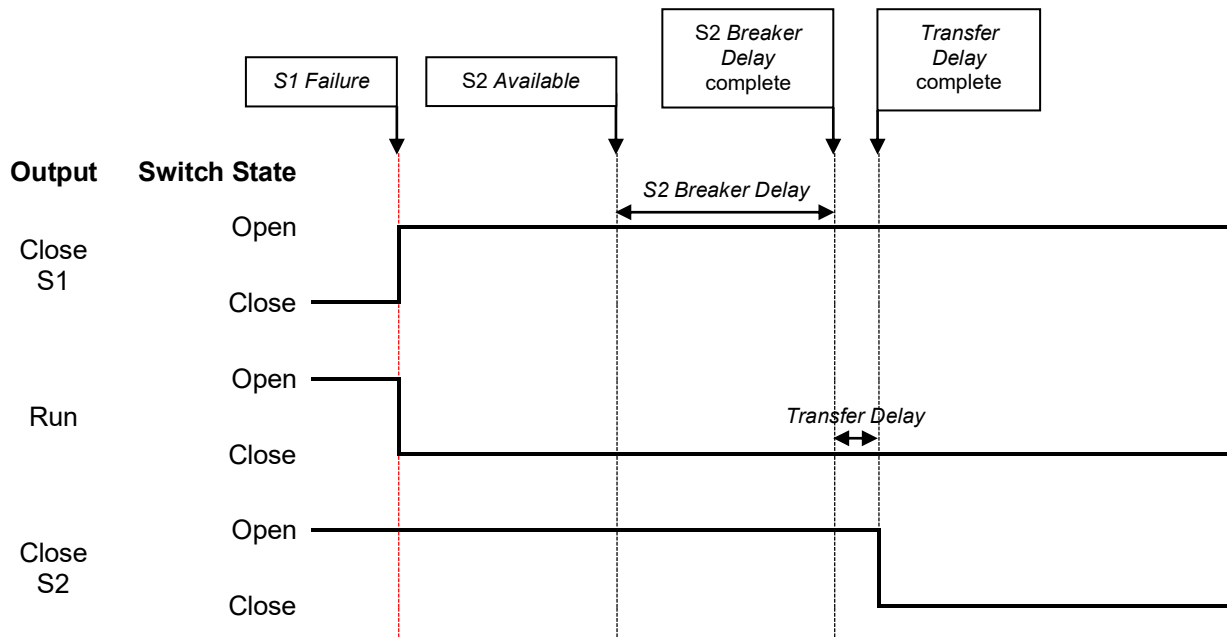

4.3.2 S1 RETURN

In this example, the S1 supply voltage has risen above the *S1 Breaker Under Voltage Return* or fallen below the *S1 Breaker Over Voltage Return*.

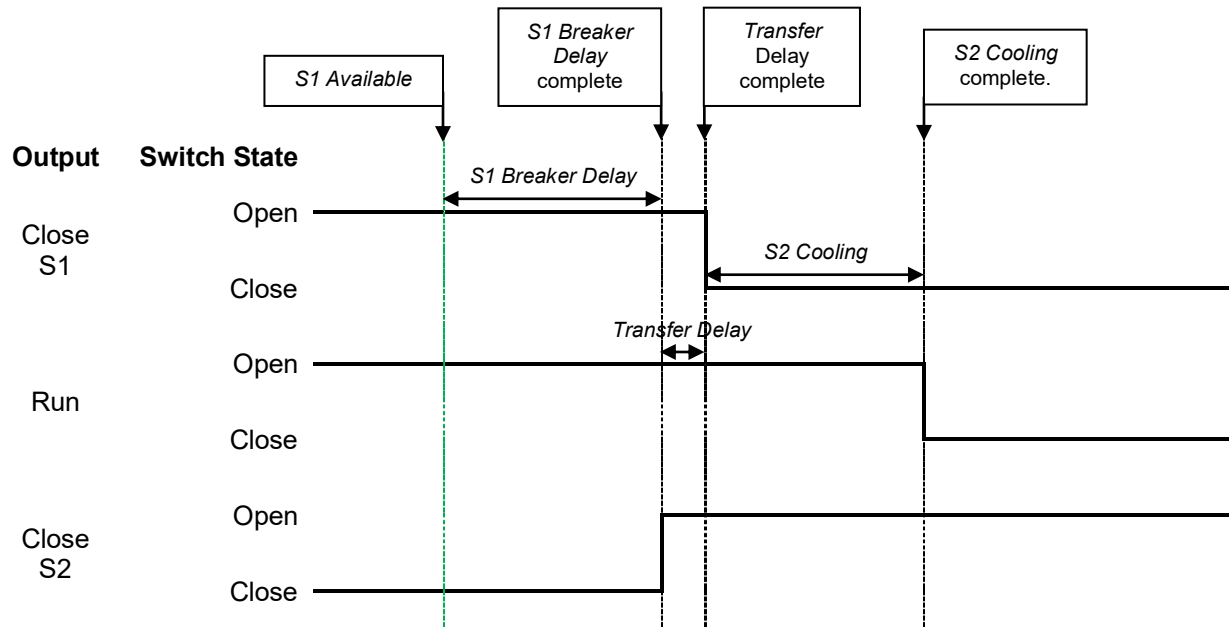

5 PROTECTIONS

NOTE: The DSE327 only provides phase to neutral voltage failure detection, frequency failure detection is not supported within this module.

NOTE: See section entitled Configuration Mode elsewhere in this document for further details on how to configure the module's nominal voltage.

Fault	110 V Variant	230 V Variant
S1/S2 Breaker Under Voltage Trip	80% of Selected Nominal Voltage	80% of Selected Nominal Voltage
S1/S2 Breaker Under Voltage Return	90% of Selected Nominal Voltage	90% of Selected Nominal Voltage
S1/S2 Breaker Over Voltage Return	110% of Selected Nominal Voltage	110% of Selected Nominal Voltage
S1/S2 Breaker Over Voltage Trip	120% of Selected Nominal Voltage	120% of Selected Nominal Voltage

6 CONFIGURATION MODE

NOTE: *Configuration Mode* is only available on module hardware version 0327-002-xx and above. For hardware version 0327-001-xx the nominal voltage is fixed to 110 V or 230 V depending upon the module variant.

The *S1 Breaker Delay Timer* is used as a configuration selector when the *Configuration Mode* is entered.

In this mode it is possible to adjust the nominal voltage of the module between a number of preconfigured options to allow support for different operating voltages.

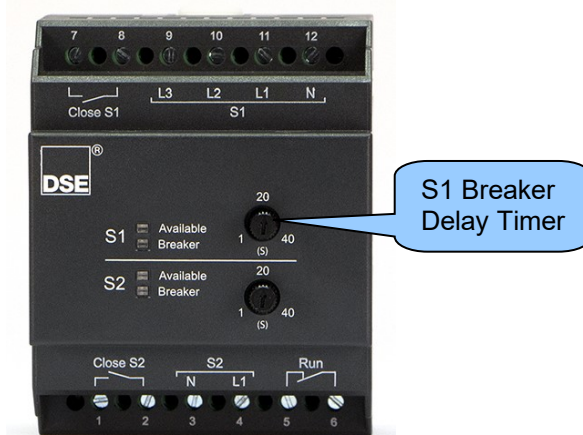

6.1 ENTERING CONFIGURATION MODE

NOTE: Remember to record the position of the *S1 Breaker Delay Timer* before making adjustments as the position needs to be reset once a new configuration has been selected.

NOTE: When the *Configuration Mode* is active, the *Close S1* & *Close S2* outputs remain open until normal control is resumed. The module reboots when *Configuration Mode* is exited.

Configuration Mode is only accessible when both S1 and S2 supplies are available.

To activate *Configuration Mode* the *S1 Breaker Delay Timer* must be rotated fully anti-clockwise, then fully clockwise twice in quick succession.

Only the *S2 Breaker LED* illuminates when the *Configuration Mode* is accessed.

6.2 SELECTING THE CONFIGURATION

In *Configuration Mode* the module facia LEDs indicate the selected configuration.

Upon entering *Configuration Mode*, the default configuration is always selected due to the *S2 Breaker Delay Timer* being turned fully anti-clockwise. As the *S2 Breaker Delay Timer* is rotated clockwise, additional LEDs illuminate to indicate which configuration is selected.

The following tables display the status of the LEDs when each configuration is selected.

230 V Variant	S1 Available LED	S1 Breaker LED	S2 Available LED	S2 Breaker LED
230 V	Unlit	Unlit	Unlit	Lit
220 V	Unlit	Unlit	Lit	Lit

110 V Variant	S1 Available LED	S1 Breaker LED	S2 Available LED	S2 Breaker LED
110 V	Unlit	Unlit	Unlit	Lit
120 V	Unlit	Unlit	Lit	Lit
127 V	Unlit	Lit	Lit	Lit

6.3 SAVING THE CONFIGURATION

The selected configuration is saved to the module when the *S1 Breaker Delay Time* remains unmoved for a period of 10 seconds.

Upon saving, two of the module LEDs illuminate for two seconds to indicate either a successful or failed save. The table below indicates the LEDs that illuminate in either scenario.

Save Status	S1 Available LED	S1 Breaker LED	S2 Available LED	S2 Breaker LED
Success	Lit for 2 seconds	Unlit	Lit for 2 seconds	Unlit
Failure	Unlit	Lit for 2 seconds	Unlit	Lit for 2 seconds

The module reboots upon the *Configuration Mode* being exited.

7 MAINTENANCE, SPARES, REPAIR AND SERVICING

The DSE327 Series controller is designed to be *Fit and Forget*. As such, there are no user serviceable parts within the controller.

In the case of malfunction, you should contact your original equipment supplier (OEM).

8 WARRANTY

DSE provides limited warranty to the equipment purchaser at the point of sale. For full details of any applicable warranty, you are referred to your original equipment supplier (OEM).

9 DISPOSAL

9.1 WEEE (WASTE ELECTRICAL AND ELECTRONIC EQUIPMENT)

If you use electrical and electronic equipment you must store, collect, treat, recycle and dispose of WEEE separately from your other waste



This Page is Intentionally Blank